



Roofing Material Specifications and Details

FOURTH EDITION



"We've Got the Highest Technology to Stop the Smallest Leak"

INTRODUCTION / INDEX

All specifications, materials, information designs and/or literature contained herein, which have been written by the Manufacturer, is given for the sole purpose of aiding the architect, designer, roofing contractor and specification writer in preparing a system to suit various needs when using BITEC products as roofing membrane systems.

BITEC does not state, infer or imply that BITEC and/or its representatives are engineers, designers or architects, and that the information contained herein is the definitive method of application, however, the specifications contained herein are minimums for proper installation and for potential Warranty issuance.

BITEC merely supplies this information as a guide and accepts no responsibility for design and construction of the building, roof deck, or for uses of BITEC products not within these published specifications or recommendations without prior notice.

BITEC will absolutely not accept responsibility for damages to personal property or injuries to individuals

before, during or after application of BITEC manufactured products.

BITEC, INC. neither accepts nor recognizes any Warranty other than its own. BITEC Warranties are not transferable unless requested in writing from the Warranty holder, and approved in writing by BITEC, INC.

Approval and acceptance for warranty will only be given by BITEC Manager of Technical Services. BITEC will not issue material and labor warranties for membrane or assemblies installed over the following conditions:

- Swimming pools
- Interior high humidity conditions
- Existing systems with wet materials
- Improperly prepared existing roof surfaces
- Insulations not approved by BITEC
- Heated tanks
- Pressurized Plenums
- Freezer buildings
- Cold storage buildings
- Certain non-commercial buildings

- Storage silos or grain warehouses
- Structures with cables, struts, piping or conduits installed between the deck and roof membrane
- Structures without positive drainage or with evaporative cooling systems
- Plywood decks less than 1/2" thick
- Certain lightweight insulating concrete decks without the proper venting.
- Membranes under any type tile, shingles or pavers

BITEC reserves the right to amend, change, delete or revise any or all of the information, specifications, designs and materials contained herein without notice.

BITEC will not make inspections on non-warranted roofs, nor will we write letters stating that we have reviewed plans, details, and/or specifications, and find the conditions acceptable for the use of our material.

Questions concerning BITEC products and systems or situations not covered by this manual should be directed to: Technical Services Department • P. O. Box 497, Morrilton, Arkansas 72110 • (800) 535-8597

Our Company.....	2	SECTION 1.06Cants.....	17
BITEC PRODUCTS:		SECTION 2.00Roof Membrane Installation.....	17
The Finest Quality Products.....	3	SECTION 2.01Temporary Roofs.....	17
BITEC Products, overview.....	4	SECTION 2.02Base Sheet Fastening Requirements.....	17
APP and SBS Membranes.....	5	SECTION 2.03BITEC Modified Bitumen (Application).....	17
Cold Applied Systems.....	6	SECTION 2.04Fire Rated Membranes.....	18
Cold Applied System Adhesives.....	7	SECTION 2.05Base Flashings.....	18
System Numbers Guide, Non-Nailable Situations.....	8	SECTION 2.06Construction Details.....	19
System Numbers Guide, Nailable Situations.....	9	SECTION 2.07Coatings and Surfacing.....	19
Cap Sheets Technical Data Chart.....	10-11	SECTION 3.00Nailable Substrate Data.....	20
Base Sheets Technical Data Chart.....	12-13	SECTION 3.01Steep Slope Fastening Requirements.....	20
BITEC Warranties.....	14	SECTION 4.00General Design Criteria for Roof Decks.....	20
GENERAL REQUIREMENTS SECTION:		SECTION 4.01Expansion Joints.....	21
SECTION 1.00Handling and Storage.....	15	SECTION 4.02Vapor Retarders.....	21
SECTION 1.01Phasing.....	15	SECTION 4.03Pressurized Plenums.....	22
SECTION 1.02Asphalt.....	15	SECTION 4.04Construction Details.....	22
SECTION 1.03Asphalt Application.....	16	SECTION 4.05Other Design Criteria.....	22
SECTION 1.04Asphalt Temperatures.....	16	SECTION 5.00Roof Decks (General).....	22
SECTION 1.05Cut Backs, Emulsions, Reflective Coatings.....	17	SECTION 5.01Steel Decks.....	22
		SECTION 5.02Poured Structural Concrete.....	23
		SECTION 5.03Pre-Stressed or "TT" Sections.....	23

INDEX

SECTION 5.04	Lightweight Insulating Concrete	23
SECTION 5.05	Wood Plank Decks	24
SECTION 5.06	Plywood Decks	24
SECTION 5.07	Poured Gypsum Decks	24
SECTION 5.08	Structural Wood Fiber Decks	24
SECTION 5.09	Open Beam Ceilings	24
SECTION 5.10	Wood Nailers	25
SECTION 6.00	Reroofing Preparation and Field Conditions	25
SECTION 6.01	Additional Precautions	25
SECTION 6.02	Insulation	26
SECTION 6.03	Roof Insulation, Double Layer Application	26
SECTION 6.04	Roof Insulation, Mechanical Attachment	26
SECTION 6.05	Insulation and Roof System Application	26
SECTION 6.06	Base Sheet Requirements	27
SECTION 6.07	UL Listings	27
SECTION 6.08	FM Systems Approval	27
SECTION 7.00	Reroofing (Retrofit)	27
SECTION 7.01	Reroofing Specification RGS-01	27
SECTION 7.02	Reroofing Specification RSS-02	28
SECTION 7.03	Statement of Acceptance	28
SECTION 7.04	Pressure Relief Vents	28
SECTION 8.00	Application Safety	28
SECTION 8.01	Personnel	28
SECTION 8.02	Fire Prevention	28
SECTION 8.03	Code Authority	28
SECTION 8.04	Equipment Do's	29
SECTION 8.05	Equipment Don'ts	29
SECTION 8.06	Building Do's	29
SECTION 8.07	Building Don'ts	29
	Roof Inspections and Maintenance	30
	Fasteners	31

CONSTRUCTION DETAILS:

Introduction and Table of Drawings	32
------------------------------------	----

ROOFING DETAIL DRAWINGS:

DETAIL #1	Draining Edge with Gutter	33
DETAIL #1a	Draining Edge with Gutter, alternate	33
DETAIL #2	Flat Draining Edge (Drip Edge, Gravel Stop)	34
DETAIL #2a	Flat Draining Edge, alternate	34
DETAIL #3	Raised Roof Edge (with Cant Edge)	35
DETAIL #4	Low Raised Edge (with Tapered Edge)	35
DETAIL #4a	Low Raised Edge (w/Tapered Edge), alternate	36
DETAIL #5	Typical Parapet Wall (for 2-ply Systems)	36
DETAIL #6	Parapet Wall End Termination	37
DETAIL #7	Multi-Ply Base Flashing at Plywood Parapets	37
DETAIL #7A	High Parapet Base Flashing at Plywood Walls	38
DETAIL #7B	High Parapet Base Flashing, Masonry Walls	38
DETAIL #7C	Multi Ply Base Flashing, Masonry Walls,	39
DETAIL #7D	Multi-ply Base Flashing, Stone Capped Walls,	39
DETAIL #7E	Multi-ply Base Flashing, EIFS walls	40
DETAIL #8	Base Flashing for Wall Supported Deck	40
DETAIL #9	Base Flashing for Non Wall Supported Deck	41
DETAIL #10	Base Flashing for Vented Base Sheet	41
DETAIL #11	Typical Termination Bar Counterflashing	42

DETAIL #12	Area Divider Curb	42
DETAIL #13	Curb Type Expansion Joint	43
DETAIL #14	Low Profile Raised Expansion Joint	43
DETAIL #14A	Low Profile Prefabricated Expansion Joint	44
DETAIL #15	Thru-Wall Scupper	44
DETAIL #16	Scupper Through Raised Roof Edge	45
DETAIL #17	Roof Drain without Lead Flashing	45
DETAIL #18	Roof Drain with Lead Flashing	46
DETAIL #19	Sheet Metal Pan Roof Drain	46
DETAIL #20	Skylight, Hatch and Smoke Vent Curbs	47
DETAIL #21	Roof Top Air Handling Units	47
DETAIL #22	Insulated Steel Deck Frame Support	48
DETAIL #23	Concrete Deck Frame Support	48
DETAIL #24	Pipe Support with Roller Assembly	49
DETAIL #25	Equipment or Sign Support Rail	49
DETAIL #26	Pipe and Flashing Clearances	50
DETAIL #27	Mechanical Equipment Stand	50
DETAIL #28	Plumbing Vent Flashing	51
DETAIL #29	Approved One-Way Roof Vent	51
DETAIL #30	Hot Stack Flashing Curb	52
DETAIL #31	Piping Through Roof Deck	52
DETAIL #32	Typical Pitch Pan	53
DETAIL #33	Split Repair	53

ROOF ASSEMBLY:

General Requirements and Introduction	54
---------------------------------------	----

LAYING PATTERN DIAGRAMS:

#1	Typical Three-Ply System Over Insulation	55
#2	3-Ply System, Mech. Attached Base Sheet & Insulation	55
#3	Mechanically Attached Base Sheet and Insulation	56
#4	Nailable Deck, without Insulation	56
#5	Nailable Lightweight Concrete Deck	57
#6	Concrete Deck - Fully Adhered	57
#7	Mechanically Attached Insulation, Mopped Base Sheet	58
#8	Typical Re-Cover System	58

BUR MOD SYSTEMS:

Introduction and Index	59
Installation Parameters	60
Approved Products, Specification Numbers Chart	61
Typical Laying Pattern Diagrams	62-63

BUR-MOD SPECIFIC DETAIL DRAWINGS:

BM #1	Draining Edge with Gutter	64
BM #1a	Draining Edge with Gutter, alternate	64
BM #2	Flat Draining Edge, Drip edge, Gravel Stop	65
BM #2a	Flat Draining Edge, Drip edge, Gravel Stop, alternate	65
BM #7	Multi-Ply Base Flashing at Plywood Parapets	66
BM #7A	Base Flashing at Plywood Parapets	66
BM #7B	High Parapet Base Flashing at Masonry Walls	67
BM #7C	Multi-Ply Base Flashing at Masonry Parapets	
BM #28	Plumbing Vent Flashing	68
BM #30	Hot Stack Flashing Curb	68

Notes	Inside Back Cover
-------	-------------------

OUR COMPANY

Committed to Service and Excellence

BITEC, INCORPORATED

(Pronounced Bee-tek) is a premier modified bitumen membrane manufacturer for the demanding specifier, architect, property owner or contractor who expects quality products and service to support their business and investment needs.

From our beginning in 1986, BITEC has formulated and produced high quality modified bituminous roofing and waterproofing membranes, marketed through distribution throughout the U.S. and Canada.

Our partner in technology, INDEX S.p.A., is a world leader in the manufacture of modified bitumen membranes. Today, BITEC has become well-known throughout the roofing industry as a leader in quality and service.

Specializing only in the manufacture of modified bituminous membranes, BITEC offers our customers over 60 years of combined membrane manufacturing experience, both in development of technology and the manufacture of roofing and waterproofing membranes.

BITEC excels in this by concentrating only on the manufacture of the finest quality modified bituminous membranes, without diversification to other segments of the roofing industry.

OUR STATE-OF-THE-ART MANUFACTURING FACILITY

Our plant in Morrilton, Arkansas, features the most recent developments in modified bitumen manufacturing, along with integrated technological advances through our partners at INDEX. This capability provides the customer with the highest quality products in the market today.

Our location places us in close proximity to the finest crude oil sources which are recognized as being the most compatible asphalt available for polymer modification.

UNEQUALLED TECHNICAL SERVICE AND SUPPORT

Our technical department is staffed with roofing industry professionals, and is always available to discuss your project in a timely and thorough manner.

BITEC is dedicated to providing complete project assistance and comprehensive technical support in all phases of your construction, from planning to installation.

BITEC can also supply you with a wide range of up-to-date technical publications which cover most types of roofing and waterproofing requirements.

LET BITEC SHOW YOU HOW

BITEC sponsors many seminars throughout the U.S., on modified bitumen products and systems, featuring application and hands-on techniques. You can be informed of changes in materials, regulations, trends, techniques or potential problems that affect your business.

OUR GREAT LOCATION MEANS FAST SHIPPING

Our central U.S. location and close proximity to truck, rail and barge transportation will allow BITEC to expedite shipments to any location in the nation, and a mild local climate means minimal shipping problems.

QUALITY PRODUCTS PROVIDE QUALITY WARRANTIES

BITEC recognizes your requirements for quality; we constantly demand it of ourselves and our products. The consistent high quality of our membranes allows us to offer not only the industry standard, but also warranties that can range in coverage up to 20 years for workmanship and materials.



Even after 10,000 stress cycles on a section of membrane, this BITEC material showed no breakage or tearing.



Bending tests performed at -22°F (-30°C) proved BITEC materials to be excellent for use in the coldest of climates.



In repeated puncture tests, SBS membranes showed excellent resistance to penetration and perforation.



The tensile strength of unreinforced BITEC SBS allows 1500% elongation without breakage.

THE FINEST QUALITY PRODUCTS

Superior Quality from the Start

Our membranes are produced with the highest quality made-on-purpose polymers obtainable today, and blended with distilled asphalt, insuring consistent modification and product performance. Our APP and SBS modified bitumen products yield the best flexibility, durability and workability properties of any product available.

QUALITY REINFORCEMENTS MAKE THE DIFFERENCE

We use Spunbond Polyester roofing fabric as reinforcement for all of our polyester reinforced membranes.

High strength fiberglass mat is used in our "FR" (fire-rated) products as well as in most of our COMPABASE modified bitumen base sheets.

Both reinforcements provide excellent isotropic mechanical strength as well as puncture resistance.

BITEC MEMBRANES ARE EASY TO APPLY...

Our full line of APP and SBS modified bitumen membranes, both cap sheet and base sheet types, are manufactured to form a monolithic membrane, rather than being a manufactured laminated product that is pre-saturated with oxidized asphalt and containing a high stabilizer content.

The result is a quality membrane that will lay flat without wrinkles and insure proper bonding properties, while requiring less heat and less labor to install.

BITEC modified bitumen membranes are available for application

by heat welding, hot asphalt and cold adhesive methods.

THE MOST MODERN RESEARCH AND DEVELOPMENT PROCESS IN THE COUNTRY...

Our quality control laboratory and state-of-the-art testing equipment guarantees an outstanding finished product. It also insures in the future, BITEC will be at the forefront of developing new and improved products tailored specifically to your regional requirements. BITEC products meet or exceed product approval recognition of the Underwriters Laboratories, Factory Mutual Research, Metro Dade, City and County of Denver and BDA Buro Dakadvies B.V.

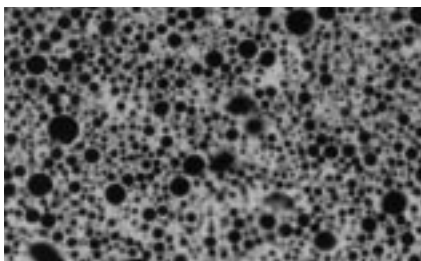

Ultraviolet microscopy shows a BITEC test batch sample as a homogeneous mixture of distilled asphalt and special modifiers. This blend insures a superior molecular composition and provides a stronger, and more elastic finished product.

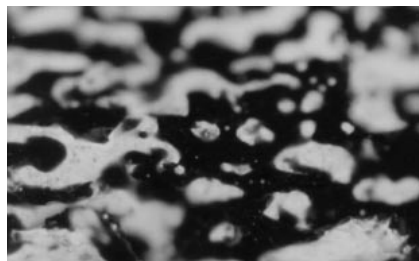

This magnification illustrates inconsistencies in a competitor's test batch largely to non-thorough blending of the base elements. The membranes produced from this formulation would probably fail most fatigue and aging tests.

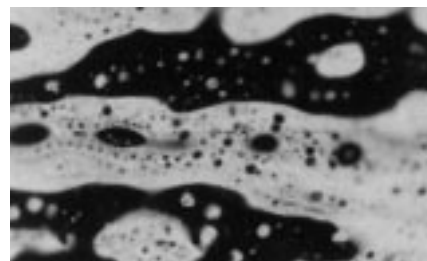

This photo shows a definite separation of the distilled asphalt-modifier blend. Membranes from this recipe would not have the desired qualities of strength, elasticity and long-life that are required to meet our high standards.

BITEC PRODUCTS

CAP SHEETS

APS-4T	Torch Applied
APM-4T	Torch Applied
APM-4.5T	Torch Applied
SPM-4.5T	Torch Applied
SPM-3.5H	Mop Applied
SPM-4H	Mop Applied
SPM-4H-250	Mop Applied
SPS-3H	Mop Applied
SFM-3.5H	Mop Applied
SFM-3.5H-FR	Mop Applied
SFM-4H-FR	Mop Applied

BASE SHEETS

FA-2T	Torch Applied
FS-2H	Mop Applied
FS-2H Plus	Mop Applied
PS-2H	Mop Applied
FS-25	Mop Applied
FS-40	Mop Applied
BFS-2H	Mop Applied
FS-2H-FR	Mop Applied
Beta Base	Mop or Mech. Attached

FIRE RATED MEMBRANES

BITEC "FR" membranes provide UL Class "A" fire-rated assemblies for slopes up to 3/4" in 12" (3/4":12") without the use of additional coating. "FR" membranes are reinforced with a high-strength fiberglass mat.

MINERAL DESIGN

BITEC's "Mineral Design" cap sheet membranes provide an attractive design to otherwise ordinary roof areas. Mineral design is available in both APP (MDA) and SBS (MDS), in eight patterns and 13 granule colors.

POLYMER ADHESIVES

For application of mop grade membrane sheets: PMA-186 for squeegee, roller or brush application and trowel grade PMA-2000. Both are excellent for filling pitch pans and sealing penetration flashings.

PRODUCT NAMES - CAP SHEETS using example: APS-4T

- A** - ModifierA = APP or S = SBS
- P** - Reinforcement.....P = Polyester, F = Fiberglass
- S** - SurfaceS = Smooth, M = Mineral
- 4** - Thickness2, 3, 3.5, 4 or 4.5 Millimeters
- T** - ApplicationT = Torch, H = Hot Asphalt

PRODUCT NAMES - BASE SHEETS using example: FS-2H

- F** - Reinforcement.....P = Polyester, F = Fiberglass
- S** - ModifierS = SBS or A = APP
- 2** - Thickness1, 2, or 2.2 Millimeters
- H** - ApplicationT = Torch, H = Hot Asphalt

FR - Fire Rated; Class "A" UL-Rated Cap sheets and Base sheets

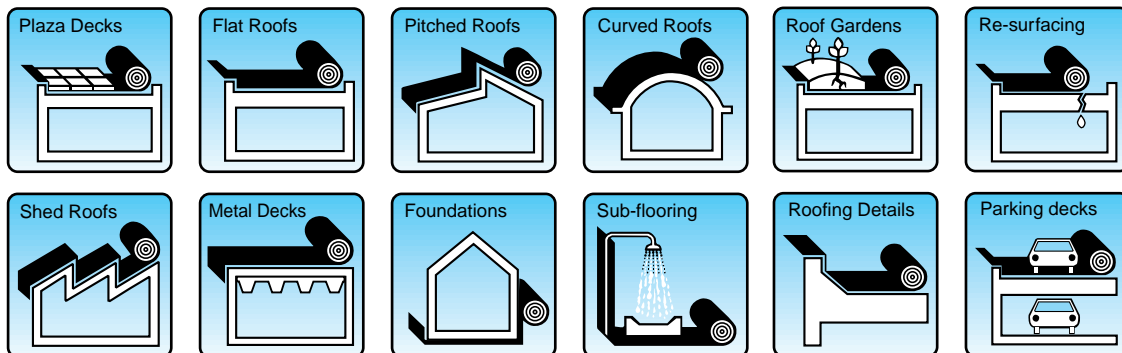

APP MEMBRANES

Versatile, Long Lasting and Weather Resistant

BITEC APP modified bitumen membranes are composed of select APP polymers blended with distilled asphalt and reinforced with a Spunbond Polyester fabric.

All BITEC APP membranes are installed by **HEAT WELDING** and have the following characteristics:

- High melting temperatures
- Flexibility at low temperatures
- High resistance to thermal degradation
- Resistance to ultraviolet light degradation.
- Excellent substrate adhesion
- Resistance to most acids and bases
- Impermeability to water

BITEC APP modified bitumen membranes may be used to waterproof prefabricated concrete roofs, roof systems with metal and wood decks, thermal insulations, paved roofs or walkways, foundations, and constructions such as multi-story parking decks.

BITEC APS-4T, a smooth surfaced APP modified bitumen membrane, can be coated or left uncoated according to the specific system specification.

BITEC APM-4T, a mineral surfaced APP modified bitumen membrane, contains factory installed roofing granules which eliminate the need for installing a protective coating. Mineral surfacings reduce ther-

mal and ultraviolet light degradation, and slow the normal processes of membrane ageing.

BITEC membranes that are applied by heat welding contain a polypropylene and/or polyethylene covering to prevent roll blocking and provide a site indicator for proper welding temperature. These films will melt, allowing the APP modified bitumen compound to adhere to itself and the substrate being bonded to.

The only tools required for application of BITEC APP membranes are a propane gas fired roofer's torch, a round nose roofer's trowel, a hookblade roofer's knife and a pair of fire resistant gloves.

SBS MEMBRANES

Strong and Flexible for Demanding Applications

BITEC SBS modified bitumen membranes are composed of styrene-butadiene-styrene thermoplastic rubber, blended with distilled asphalt and reinforced with a Spunbond Polyester fabric or high strength fiber glass mat.

BITEC SBS membranes are manufactured to suit a variety of application methods, and possess the following characteristics:

- Impermeability to water
- Outstanding flexibility at very low temperatures
- Resistance to thermal aging
- Excellent substrate adhesion
- Resistance to perforation
- Superior elasticity
- Excellent mechanical and fatigue strength
- Tear resistance
- Dimensional stability

It is necessary to have a factory installed or on-site installed surfacing on SBS modified bitumen membranes, therefore, most of BITEC's SBS modified bitumen membranes come with factory installed roofing granules for this purpose.

With our smooth surfaced product SPS-3H, a site installed surfacing of either a flood coat and gravel, or approved roof coating must be applied for ultraviolet light protection.

OUR SPM and SFM family of membranes contain factory installed roofing granules eliminating the need to add on-site surfacings.

Tools required for the proper application of these products are detailed in the BITEC product manual and technical bulletins relative to the specific SBS modified bitumen membrane being used.

For heat welded systems, bonding is performed with a propane gas fired roofer's torch.

For hot asphalt applied systems, bonding is performed with the use of ASTM D312 Type III, or Type IV roofing asphalt applied with conventional equipment.

For cold adhesive applied systems, bonding should be performed with BITEC elastomeric adhesives, or with any BITEC approved elastomeric adhesives. For all applications, the membrane should be laid out, aligned and completely bonded to the substrate as prescribed in the project's written specification, and is contingent upon the specific method of application.

Particular care should be taken to ensure that all seams or laps are completely sealed.

As always, good roofing practices should be considered and used.

COLD APPLIED SYSTEMS

INTRODUCTION

BITEC's cold adhesive applied SBS modified bitumen membranes give you better security and performance than conventional roll roofing products made with oxidized asphalt.

Their application range covers a variety of slopes and deck configurations. From 1/4" in 12" up to 3" in 12", the membrane is functional. Another advantage is that hot asphalt and open flame are not required for installation. This reduces the potential for fire.

A specially formulated cold adhesive is used to install the membrane. After a short curing time the cold adhesive applied system forms a flexible, durable, watertight system that will outlast conventional roofing systems.

PRODUCTS

BITEC SBS modified bitumen membranes SPM-3.5H and SFM-3.5H are recommended for use by this method. However, any BITEC sand surfaced SBS modified bitumen product can be installed using cold applied adhesives. These membranes are tear and puncture resistant, have excellent flexibility and performance as opposed to conventional organic and fiberglass reinforced blown asphalt coated membranes.

BITEC SBS modified bitumen membranes are composed of distilled asphalt modified with SBS thermoplastic rubber. A high strength fiberglass or polyester reinforcement is used as support.

ADHESIVES

BITEC PMA 186 field grade SBS modified bitumen adhesive is recommended for use on low slope applications, while PMA 2000, trowel grade SBS modified bitumen adhesive is recommended for all flashings and higher slope applications.

Both adhesives contain an SBS thermoplastic rubber as a modifier,

ensuring complete compatibility between the cap sheet and the adhesive.

GENERAL REQUIREMENTS

Follow all good roofing practices, and BITEC specifications when installing adhesive applied membranes. Base sheet and insulation must be mechanically attached to deck.

Use only BITEC SBS modified bitumen membranes having sand on the bottom surface and granules on the top surface. (SPM-3.5H or SFM-3.5H).

Adhesive may be applied at temperatures between 55° F and 120° F. Only BITEC approved adhesives should be used to install these membranes. Follow adhesive manufacturer's application rates when installing these membranes. Typically, application rates will be 1½ gallons per 100 ft². Apply adhesive by notched squeegee with notches 1/4" long, 1/8" deep and spaced 1" on center, or by using a three knot brush or notched trowel.

Trowel grade flashing cement should be applied 1/8" thick over the area receiving the flashing membrane at an application rate of 1 gal. per 20 sq. ft. or 5 gal. per 100 sq. ft.

Deck should be built with 1/2" min. plywood or 3/4" min. wood boards. Deck shall be dry, smooth and free of debris. Deck should be built to provide 1/4" in 12" minimum slope.

Base sheet should be UL Listed Type G2 or 43# organic. Base sheet must be attached using suitable fasteners (i.e. Simplex nails) 9" on the laps and stagger nailed 18" o.c. in the field.

Flashing material shall be the same material used for field membrane. Slopes above 3/4:12 require the base sheet and membrane to be installed parallel to the slope with base sheet fastened as noted above. The cap sheet membrane should be blind fastened at end laps, 2" from the top edge and 6" o.c. across the sheet width, using nails and tin discs or screws and plates.

- Performs Better than Conventional Roll Roofing
- No Hot Asphalt or Open Flame Required
- Excellent Tear and Puncture Resistance
- Easy to Apply, Easy to Maintain
- Excellent Cold Flexibility

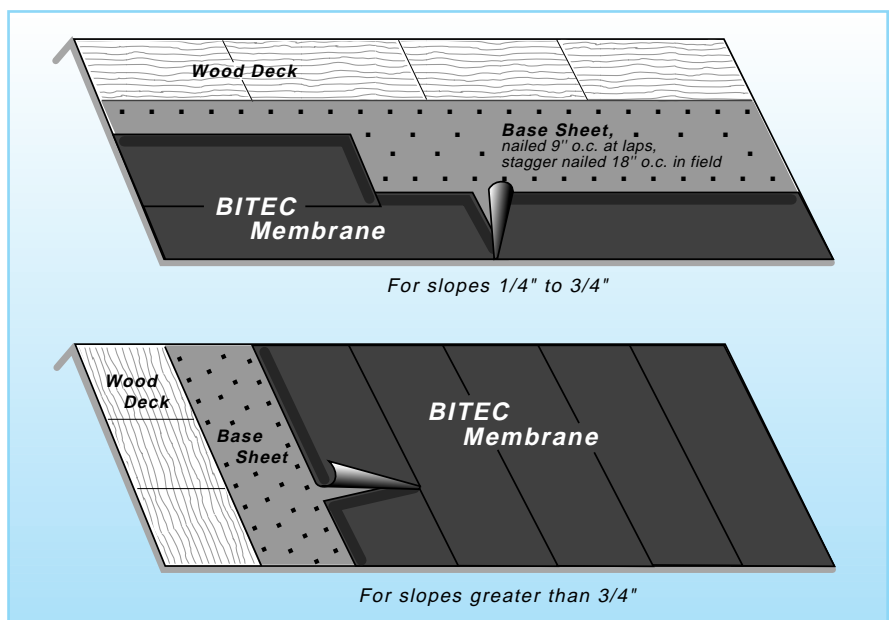

COLD APPLIED SYSTEM ADHESIVES

PMA-186

POLYMER MODIFIED ADHESIVE For Squeegee, roller or brush application.

PMA-186 is a fibrated, heavy bodied, SBS rubberized, modified asphalt adhesive, blended with the highest quality bitumen.

USES: For application of mop grade SBS modified bitumen membrane sheets in lieu of mopping asphalt.

An excellent product for filling pitch pans and sealing penetration flashings on SBS roof membranes.

Torch grade SBS modified bitumen membranes and APP modified bitumen membranes cannot be installed with this product.

It is highly recommended to aluminum coat or embed roofing granules in the exposed adhesive for UV protection.

PMA-2000

POLYMER MODIFIED FLASHING MASTIC All Weather, Trowel Grade

PMA-2000 is a fibrated, heavy bodied, SBS rubberized, modified asphalt adhesive, blended with the highest quality bitumen.

USES: For application of mop grade SBS modified bitumen membranes and flashing sheets in lieu of PMA 186.

An excellent product for filling pitch pans and sealing penetration flashings on SBS roof membranes.

Torch grade SBS modified bitumen membranes and APP modified bitumen membranes cannot be installed with this product.

It is highly recommended to aluminum coat or embed roofing granules in the exposed adhesive for UV protection.

INSTALLATION

The adhesive should be applied using a notched squeegee, brush or trowel, following the guidelines and application rates set forth in BITEC technical publications relative to cold adhesive application.

Special care should be taken not to over-apply the adhesive. Over-application can cause degradation of the membrane.

Positive drainage should always be provided in order to prevent ponding water.

Never install more than one ply of membrane in adhesive. Multi-ply application is not recommended.

A typical system would be composed of a nailed UL Listed G2 fiberglass reinforced base sheet, with the adhesive applied BITEC cap sheet installed as the finished surface.

DANGER - Keep out of the Reach of children and pets. Combustible material. Product is for commercial or industrial use. Harmful or fatal if swallowed. Contains petroleum mineral spirits.

If swallowed, do not induce vomiting. Call physician or poison control center immediately. For contact with skin, wash with soap and water.

Do not use solvent or mineral spirits to clean hands. For eye contact, flush eyes with copious amount of water and seek medical attention immediately.

This material is combustible. Keep away from heat source, fire or flame. Store materials in original containers. Do not use this container for anything other than its intended use.

Dispose of empty container as dictated by local code. Close container after each use. Avoid breathing mist or vapor. Use in well ventilated area.

For warranty information governing cold adhesive applied membrane products, contact BITEC's Technical Services Department.



	PMA-186	PMA-2000
Nominal Weight	8.25 lb. / gal.	8.5 lb. / gal
SBS Rubber	8% by solids	7.5% by solids
Cure Time	Tacks in 20 min., Dries in 2-5 days. Cures within 2 weeks, forming elastic bond.	
Application Rate	67 sq. ft./gal. or 1.5 gal./100 sq. ft.	1/8" Thick, 20 sq. ft. / gal. or 5 gal./100 sq. ft.

Exceeds all parameters of ASTM D 3019 and SCC 153.

SYSTEM NUMBERS GUIDE

NON-NAILABLE (.1) and NAILABLE (.2) DEFINITIONS

BITEC defines non-nailable specifications as those "situations" where no fasteners are used in the entire new roof system.

Nailable specifications include all "situations" where fasteners of any type have been used within the new roof system.

EXAMPLES:

A concrete deck normally considered to be a non-nailable deck, would be considered a nailable deck if insulation or base sheet was mechanically fastened.

Therefore, APM-4T.2 designates a roof system using mechanical fasteners and an APM-4T cap sheet. APM-4T.1 would designate a roof system without fasteners and an APM-4T cap sheet.

WARRANTY PERIOD DESIGNATIONS

All specifications for warranty systems other than the 10-year systems must be pre-approved by BITEC's Technical Services Department.

Warranty periods other than 10 years are designated by the addition of **.12** for 12 years, **.15** for 15 years or **.20** to indicate a 20-year warranty period.

NON-NAILABLE SITUATIONS

For new or replacement systems • For Hybrid Systems, see BUR-MOD Section, pgs. 59-68

	System Number	Insulation Required*	No. of Plies	Base Sheet Non-modified	First Ply, Modified	Second Ply, Modified	Third Ply, Modified	Additional Surfacing
10-12 YEAR	APS-4T.1	10-yr. No; 12-yr. Yes	2	BETA BASE	APS-4T	—	—	**OPTIONAL
	APM-4T.1	10-yr. No; 12-yr. Yes	2	BETA BASE	APM-4T	—	—	—
	APM-4.5T.1	10-yr. No; 12-yr. Yes	2	BETA BASE	APM-4.5T	—	—	—
	SPM-4.5T.1	10-yr. No; 12-yr. Yes	2	BETA BASE	SPM-4.5T	—	—	—
	SPM-3.5H.1	10-yr. No; 12-yr. Yes	2	BETA BASE	SPM-3.5H	—	—	—
	SFM-3.5H.1	10-yr. No; 12-yr. Yes	2	BETA BASE	SFM-3.5H	—	—	—
	SFM-3.5H-FR.1	10-yr. No; 12-yr. Yes	2	BETA BASE	SFM-3.5H-FR	—	—	—
	SPS-3H.1	10-yr. No; 12-yr. Yes	2	BETA BASE	SPS-3H	—	—	COAT./GRAVEL
15 YEAR	APS-4T.1.15	Yes	3	BETA BASE	FA-2T	APS-4T	—	COATING
	APM-4T.1.15	Yes	3	BETA BASE	FA-2T	APM-4T	—	—
	APM-4.5T.1.15	Yes	3	BETA BASE	FA-2T	APM-4.5T	—	—
	SPM-4.5T.1.15	Yes	3	BETA BASE	PS-2H or FS-2H	SPM-4.5T	—	—
	SPM-3.5H.1.15	Yes	3	BETA BASE	PS-2H or FS-2H	SPM-3.5H	—	—
	SFM-3.5H.1.15	Yes	3	BETA BASE	PS-2H or FS-2H	SFM-3.5H	—	—
	SFM-3.5H-FR.1.15	Yes	3	BETA BASE	PS-2H or FS-2H	SFM-3.5H-FR	—	—
	SPS-3H.1.15	Yes	3	BETA BASE	PS-2H or FS-2H	SPS-3H	—	GRAVEL
20 YEAR	APS-4T.1.20	Yes	3	BETA BASE	APS-4T	APS-4T	—	COATING
	APS-4T.1.20	Yes	3	NONE	FA-2T	APS-4T	APS-4T	COATING
	APM-4T.1.20	Yes	3	BETA BASE	APS-4T	APM-4T	—	—
	APM-4T.1.20	Yes	3	NONE	FA-2T	APS-4T	APM-4T	—
	APM-4.5T.1.20	Yes	3	BETA BASE	APS-4T	APM-4.5T	—	—
	APM-4.5T.1.20	Yes	3	NONE	FA-2T	APS-4T	APM-4.5T	—
	SPM-4.5T.1.20	Yes	3	BETA BASE	SPS-3H	SPM-4.5T	—	—
	SPM-4.5T.1.20	Yes	3	NONE	PS-2H or FS-2H	SPS-3H	SPM-4.5T	—
	SPM-3.5H.1.20	Yes	3	BETA BASE	SPS-3H	SPM-3.5H	—	—
	SPM-3.5H.1.20	Yes	3	NONE	PS-2H or FS-2H	SPS-3H	SPM-3.5H	—
	SFM-3.5H.1.20	Yes	3	BETA BASE	SPS-3H	SFM-3.5H	—	—
	SFM-3.5H.1.20	Yes	3	NONE	PS-2H or FS-2H	SPS-3H	SFM-3.5H	—
	SFM-3.5H-FR.1.20	Yes	3	BETA BASE	SPS-3H	SFM-3.5H-FR	—	—
	SFM-3.5H-FR.1.20	Yes	3	NONE	PS-2H or FS-2H	SPS-3H	SFM-3.5H-FR	—
	SPS-3H.1.20	Yes	3	BETA BASE	SPS-3H	SPS-3H	—	GRAVEL
	SPS-3H.1.20	Yes	3	NONE	PS-2H or FS-2H	SPS-3H	SPS-3H	GRAVEL

*Exception: Add'l insulation not req'd. over light wt. insulating concrete decks or gypsum decks. **Optional approved roof coating for 10 yrs; coating req'd. for 12 yrs. **15 and 20 year warranties are available only for new construction or complete tear-off projects.**

SYSTEM NUMBERS GUIDE

using example: APS-4T.1.20

- A** = APP Modifier
- P** = Polyester Reinforcement
- S** = Smooth Surface
- 4** = 4mm Thick
- T** = Torch Applied
- .1** = Non-Nailable "Situation"
- .20** = 20-Year Warranty

using example: SFM-3.5H-FR.2.15

- S** = SBS Modifier
- F** = Fiberglass Reinforcement
- M** = Mineral Surface
- 3.5** = 3.5mm thick
- H** = Hot Asphalt Applied
- FR** = Fire Rated - UL Class A without add'l. surfacing
- .2** = Nailable "Situation"
- .15** = 15-Year Warranty

NAILABLE SITUATIONS

For new or replacement systems • For Hybrid Systems, see BUR-MOD Section, pgs. 59-68

	System Number	Insulation Required*	No. of Plies	Base Sheet Non-modified	First Ply, Modified	Second Ply, Modified	Third Ply, Modified	Additional Surfacing
10-12 YEAR	APS-4T.2	10-yr. No; 12-yr. Yes	2	BETA BASE	APS-4T	—	—	**OPTIONAL
	APM-4T.2	10-yr. No; 12-yr. Yes	2	BETA BASE	APM-4T	—	—	—
	APM-4.5T.2	10-yr. No; 12-yr. Yes	2	BETA BASE	APM-4.5T	—	—	—
	SPM-4.5T.2	10-yr. No; 12-yr. Yes	2	BETA BASE	SPM-4.5T	—	—	—
	SPM-3.5H.2	10-yr. No; 12-yr. Yes	2	BETA BASE	SPM-3.5H	—	—	—
	SFM-3.5H.2	10-yr. No; 12-yr. Yes	2	BETA BASE	SFM-3.5H	—	—	—
	SFM-3.5H-FR.2	10-yr. No; 12-yr. Yes	2	BETA BASE	SFM-3.5H-FR	—	—	—
	SPS-3H.2	10-yr. No; 12-yr. Yes	2	BETA BASE	SPS-3H	—	—	COAT./GRAVEL
15 YEAR	APS-4T.2.15	Yes	3	BETA BASE	FA-2T	APS-4T	—	COATING
	APM-4T.2.15	Yes	3	BETA BASE	FA-2T	APM-4T	—	—
	APM-4.5T.2.15	Yes	3	BETA BASE	FA-2T	APM-4.5T	—	—
	SPM-4.5T.2.15	Yes	3	BETA BASE	PS-2H or FS-2H	SPM-4.5T	—	—
	SPM-3.5H.2.15	Yes	3	BETA BASE	PS-2H or FS-2H	SPM-3.5H	—	—
	SFM-3.5H.2.15	Yes	3	BETA BASE	PS-2H or FS-2H	SFM-3.5H	—	—
	SFM-3.5H-FR.2.15	Yes	3	BETA BASE	PS-2H or FS-2H	SFM-3.5H-FR	—	—
	SPS-3H.2.15	Yes	3	BETA BASE	PS-2H or FS-2H	SPS-3H	—	GRAVEL
20 YEAR	APS-4T.2.20	Yes	3	BETA BASE	APS-4T	APS-4T	—	COATING
	APS-4T.2.20	Yes	3	NONE	FA-2T	APS-4T	APS-4T	COATING
	APM-4T.2.20	Yes	3	BETA BASE	APS-4T	APM-4T	—	—
	APM-4T.2.20	Yes	3	NONE	FA-2T	APS-4T	APM-4T	—
	APM-4.5T.2.20	Yes	3	BETA BASE	APS-4T	APM-4.5T	—	—
	APM-4.5T.2.20	Yes	3	NONE	FA-2T	APS-4T	APM-4.5T	—
	SPM-4.5T.2.20	Yes	3	BETA BASE	SPS-3H	SPM-4.5T	—	—
	SPM-4.5T.2.20	Yes	3	NONE	PS-2H or FS-2H	SPS-3H	SPM-4.5T	—
	SPM-3.5H.2.20	Yes	3	BETA BASE	SPS-3H	SPM-3.5H	—	—
	SPM-3.5H.2.20	Yes	3	NONE	PS-2H or FS-2H	SPS-3H	SPM-3.5H	—
	SFM-3.5H.2.20	Yes	3	BETA BASE	SPS-3H	SFM-3.5H	—	—
	SFM-3.5H.2.20	Yes	3	NONE	PS-2H or FS-2H	SPS-3H	SFM-3.5H	—
	SFM-3.5H-FR.2.20	Yes	3	BETA BASE	SPS-3H	SFM-3.5H-FR	—	—
	SFM-3.5H-FR.2.20	Yes	3	NONE	PS-2H or FS-2H	SPS-3H	SFM-3.5H-FR	—
	SPS-3H.2.20	Yes	3	BETA BASE	SPS-3H	SPS-3H	—	GRAVEL
	SPS-3H.2.20	Yes	3	NONE	PS-2H or FS-2H	SPS-3H	SPS-3H	GRAVEL

*Exception: Add'l insulation not req'd. over light wt. insulating concrete decks or gypsum decks. **Optional approved roof coating for 10 yrs; coating req'd. for 12 yrs. **15 and 20 year warranties are available only for new construction or complete tear-off projects.**

CAP SHEETS

ADVANTAGES

BITEC modified bitumen cap sheet products are specially designed for the modern roofing professional. Select distilled asphalt and on-purpose made polymers are used in all of our blends. Reinforcement is with polyester fabric or fiberglass mat. Our state-of-the-art engineering and technology provide you with the highest quality waterproofing and roofing membranes, roll for roll. Combining this quality with the know-how to get the job done, BITEC products come with professional service and excellent technical assistance.

Unlike conventional oxidized asphalt products, BITEC modified bitumen cap sheet products are flexible, easy to install high-performance

membranes, available with smooth or mineral surfaces. Modified bitumen compounds are formulated and tested for every batch of product produced. All BITEC products are quality control monitored throughout the manufacturing process.

Mineral surfacing can be supplied in a variety of colors. Parting agents such as talc, sand and polymer films are used to facilitate application. Selvedge edge and ply stripes are provided in various configurations.

PREPARATION

Careful surface preparation is important. Surfaces must be clean, visibly dry, smooth and covered with a UL Listed G2 base sheet using a fiberglass reinforcement. All acces-

sories required for the installation shall be on hand prior to commencement of work wherever possible.

Any blisters, wet roofing materials, or deteriorated decking shall be removed and replaced.

Masonry surfaces and metal surfaces shall be primed with an ASTM D41 asphalt primer. Primer shall be allowed to dry completely before the membrane is installed.

INSTALLATION

Product names for BITEC give the method of application. All products having T as the ending, such as APS-4T, are for torch application only. Products having H as an ending are for hot asphalt application as well as cold adhesive, such as SPM-3.5H.

	APS-4T* TORCH APPLIED	APM-4T** TORCH APPLIED	SFM-3.5H MOP APPLIED	SPS-3H MOP APPLIED	
MODIFIER <small>APP = Atactic Polypropylene, SBS = Styrene Butadiene Styrene</small>	APP	APP	SBS	SBS	
APPROX. ROLL SIZE <small>(Flashing width rolls available)</small>	33.5' x 3.28'	32.80' x 3.28'	33.9' x 3.28'	33.5' x 3.28'	
SEAM WIDTH	3" Line	3.5" Selvedge	3.5" Selvedge	3" Line	
APPROX. COVERAGE	100 ft ²	97 ft ²	100 ft ²	100 ft ²	
TOP SURFACE <small>(Standard colors; buff, white, black)</small>	Smooth / Talc	Mineral	Mineral	Fine Sand	
BOTTOM SURFACE	Burn-off Polyethylene	Burn-off Polyethylene	Sand	Sand	
NOMINAL THICKNESS	4 mm	4 mm	3.5 mm	3 mm	
NOMINAL WEIGHT	90 lb.	107 lb.	100 lb.	73 lb.	
REINFORCEMENT	Spunbond Polyester	Spunbond Polyester	Fiberglass	Spunbond Polyester	
<small>ASTM D-36</small> SOFTENING POINT	302°F (150°C)	302°F (150°C)	250°F (120°C)	250°F (120°C)	
<small>UNI-8202</small> COLD FLEX. TEMP	5°F (-15°C)	5°F (-15°C)	-13°F (-25°C)	-13°F (-25°C)	
<small>ASTM D-412</small> TENSILE STRENGTH (LB/IN)	Long. / Trans. 100.....70	Long. / Trans. 100.....70	Long. / Trans. 80.....75	Long. / Trans. 105.....75	
<small>ASTM D-412</small> % of ELONGATION TO BREAK	Long. / Trans. 50.....55	Long. / Trans. 50.....55	Long. / Trans. 30.....30	Long. / Trans. 60.....70	

*Also available with 5mm thickness; specify APS-5T

**Also available with 4.5 mm thickness; specify APM-4.5T

CAP SHEETS

Torch application is performed by using a standard propane fired roofer's torch.

Hot application is performed by installing the membrane in ASTM D312 Type III, or Type IV asphalt.

Cold Adhesive application is performed by using BITEC PMA 186, or PMA 2000 modified bitumen adhesive. **Caution: installing both the base sheet and cap sheet in cold adhesive is not recommended.**

The BITEC modified bitumen membrane shall be installed over a previously prepared substrate. Substrate with or without insulation shall have a UL Listed Type G2 fiberglass base sheet installed as a base to receive the BITEC modified bitumen membrane.

Align the roll of membrane by completely unwinding. Rewind the roll half way, install by method of design, then install other portion of roll in the same fashion.

See the individual product specification for proper side and end lap coverage, as well as for the method of application.

Installation is enhanced due to flexibility and strength of membrane, as the membrane is provided as a composite sheet.

At the completion of the day's work, a suitable night dry-in shall be provided, regardless of weather conditions. It is advisable to only roof an area that can be completed in a typical work day. Never phase the roof system.

PRECAUTIONS

As with any roofing project, safety shall be a consideration. The use of propane fired roofing installation equipment, molten asphalt and solvent based adhesives pose potential fire and burn hazards.

Adequate protective clothing such as work gloves, long sleeve shirt, long pants and durable, flat soled shoes should be worn.

The roofing contractor shall provide safety training to all his personnel covering, but not limited to: the use and storage of propane, safe installation procedures and safe working habits.

All procedures and training shall conform to local, state and federal requirements.

	SPM-3.5H MOP APPLIED	SPM-4H MOP APPLIED	SPM-4H-250 MOP APPLIED	SPM-4.5T TORCH APPLIED	SFM-3.5H-FR MOP APPLIED	SFM-4H-FR MOP APPLIED
	SBS	SBS	SBS	SBS ⁽¹⁾	SBS	SBS
	33.9' x 3.28'	32.8' x 3.28'	32.8' x 3.28'	25.58' x 3.28'	33.9' x 3.28'	33.9' x 3.28'
	3.5" Selvege	3.5" Selvege	3.5" Selvege	3.5" Selvege	3.5" Selvege	3.5" Selvege
	100 ft ²	97 ft ²	97 ft ²	75 ft ²	100 ft ²	100 ft ²
	Mineral	Mineral	Mineral	Mineral	Mineral	Mineral
	Sand	Sand	Sand	Burn-off Polypropylene	Sand	Sand
	3.5 mm	4 mm	4 mm	4.5 mm	3.5 mm	4 mm
	100 lb.	105 lb.	105 lb.	92 lb.	103 lb.	105 lb.
	Spunbond Polyester	Spunbond Polyester	Polyester 250 gm ²	Spunbond Polyester	Fiberglass	Fiberglass
	250°F (120°C)	250°F (120°C)	250°F (120°C)	250°F (120°C)	250°F (120°C)	250°F (120°C)
	-13°F (-25°C)	-13°F (-25°C)	-13°F (-25°C)	-13°F (-25°C)	-4°F (-20°C)	-4°F (-20°C)
	Long. / Trans. 105.....75	Long. / Trans. 105.....75	Long. / Trans. 120.....85	Long. / Trans. 120.....85	Long. / Trans. 120.....120	Long. / Trans. 120.....120
	Long. / Trans. 60.....70	Long. / Trans. 60.....70	Long. / Trans. 60.....60	Long. / Trans. 60.....70	Long. / Trans. 40.....40	Long. / Trans. 40.....40

(1) New SBS specifically engineered for torch application

BASE SHEETS

ADVANTAGES

COMPABASE APP and SBS modified bitumen base sheets are composed of select distilled bitumen and made-on-purpose polymers, reinforced with polyester fabric or fiberglass mat.

COMPABASE APP or SBS modified bitumen base sheets eliminate the concern of compatibility and performance between base sheet and modified bitumen cap sheet. Modified bitumen cap sheets that are bonded to oxidized bitumen coated base sheets, especially using the heat welding process, are not totally compatible. The use of COMPABASE APP and SBS base sheets eliminates this problem.

COMPABASE APP and SBS modified bitumen base sheets remove the concern that the base sheet, of oxidized bitumen, becomes the “weak link” in membrane system performance. Oxidized bitumen coated base sheets do not contain APP or SBS modifiers. They tend to be brittle and difficult to work with during cold temperatures. Modified bitumen base sheets overcome this problem.

COMPABASE APP and SBS modified bitumen base sheets when used in conjunction with BITEC cap sheets of the same modifier give the roof membrane system complete compatibility and unsurpassed 2-ply modified bitumen system performance.

INSTALLATION

COMPABASE APP and SBS modified bitumen base sheets are installed as per design. As with our modified bitumen cap sheets the product name designates the method of application.

For instance: if a product name ends in T, such as FA-2T, the membrane is suitable for torch application only. If the product name ends in H, such as FS-2H, the membrane is suitable for either hot asphalt or cold adhesive application. However, as with any base sheet, mechanical attachment of the base sheet is also allowed. (For system requirements and methods of installation, refer to technical bulletins in the BITEC

	FA-2T TORCH APPLIED	PS-2H MOP APPLIED	FS-2H MOP APPLIED	FS-2H Plus MOP APPLIED
MODIFIER <small>APP = Atactic Polypropylene, SBS = Styrene Butadiene Styrene)</small>	APP	SBS	SBS	SBS
APPROX. ROLL SIZE	49.2' x 3.28'	49.2' x 3.28'	49.2' x 3.28'	49.2' x 3.28'
SEAM WIDTH	3"	3"	3"	3"
APPROX. COVERAGE	150 ft ²	150 ft ²	150 ft ²	150 ft ²
TOP SURFACE	Sand	Sand	Sand	Sand
BOTTOM SURFACE	Polyethylene Film	Sand	Sand	Sand
NOMINAL THICKNESS	2 mm	2 mm	2 mm	2.2 mm
NOMINAL WEIGHT	70 lb.	70 lb.	70 lb.	80 lb.
REINFORCEMENT	Fiberglass	Spunbond Polyester	Fiberglass	Fiberglass
<small>ASTM D-36</small> SOFTENING POINT	302°F (150°C)	240°F (116°C)	240°F (116°C)	240°F (116°C)
<small>UNI-8202</small> COLD FLEX. TEMP	14°F (-10°C)	14°F (-10°C)	14°F (-10°C)	14°F (-10°C)
<small>ASTM D-412</small> TENSILE STRENGTH (LB/IN)	Long. / Trans. 78.....67	Long. / Trans. 105.....80	Long. / Trans. 80.....70	Long. / Trans. 80.....70
<small>ASTM D-412</small> % of ELONGATION TO BREAK	Long. / Trans. 6.....6	Long. / Trans. 50.....50	Long. / Trans. 6.....6	Long. / Trans. 6.....6

BASE SHEETS

Product Guide for complete details.)

Torch application is performed by using a standard propane fired roofer's torch.

Hot application is performed by installing the base sheet in ASTM D312 Type III, or Type IV asphalt.

Cold Adhesive application is performed by using BITEC PMA 186, or PMA 2000 SBS modified bitumen adhesive. **Caution: installing both base sheet and cap sheet in cold adhesive is not recommended.**

PRECAUTIONS

As with any roofing project, safety shall be a consideration. The use of propane fired roofing installation

equipment, molten asphalt and solvent based adhesives pose potential fire and burn hazards.

Adequate protective clothing such as work gloves, long sleeve shirt, long pants and durable, flat soled shoes should be worn.

The roofing contractor shall provide safety training to all his personnel covering, but not limited to: the use and storage of propane, safe installation procedures and safe working habits. All procedures and training shall conform to local, state and federal requirements.

When using COMPABASE APP and SBS modified bitumen base sheets it is recommended that only base sheet and cap sheet having

the same modifier be used together. **Never mix an APP with an SBS membrane, and vice versa.**

ADVANTAGES

- System compatibility
- Two-Ply modified bitumen system
- Superior flexibility
- Excellent weatherability
- Easy to apply
- Keeps your BITEC modified bitumen roof system in total performance
- Warranty periods of up to twenty years

	FS-40 MOP APPLIED	FS-25 MOP APPLIED	BFS-2H MOP APPLIED	FS-2H-FR MOP APPLIED	BETA BASE* MOP APPLIED
	SBS	SBS	SBS	SBS	Oxid. Asphalt
	65.6' x 3.28'	98.8' x 3.28'	49.2' x 3.28'	49.2' x 3.28'	108 x 36"
	3"	3"	3"	3"	2"
	200 ft ²	300 ft ²	150 ft ²	150 ft ²	324 ft ²
	Sand	Sand	Sand	Sand	Sand
	Sand	Sand	Sand	Sand	Sand
	1.5 mm	1 mm	2 mm	2 mm	1 mm
	80 lb.	75 lb.	70 lb.	70 lb.	75 lb.
	Fiberglass	Fiberglass	Spunbond Polyester	Fiberglass	Fiberglass
	240°F (116°C)	240°F (116°C)	240°F (116°C)	240°F (116°C)	210°F (99°C)
	14°F (-10°C)	14°F (-10°C)	14°F (-10°C)	14°F (-10°C)	N/A
	Long. / Trans. 75.....60	Long. / Trans. 75.....60	Long. / Trans. 105.....80	Long. / Trans. 80.....70	Long. / Trans. 50.....55
	Long. / Trans. 6.....6	Long. / Trans. 3.....3	Long. / Trans. 50.....50	Long. / Trans. 6.....6	Long. / Trans. 2.....2

*UL Type G2; ASTM D 4601-98, Type II

BITEC WARRANTIES

BITEC PRODUCTS

All warranties are “limited” unless they are explained, termed or titled “unlimited” warranties. Any one limitation makes a warranty “limited”. Most roofing manufacturers no longer provide “bonded” roofs, but furnish limited roof warranties. Most all roof warranties have a list of exceptions which “limit” their coverage.

BITEC offers several types of warranties. **Limited Material Warranties** (Material Only Warranties) are available for 10 and 12 year periods for all BITEC products except ISA-4T and UDL-40. These warranties are normally available to the contractor or individual at time of purchase at one of our distributors.

ISA-4T may only receive a 10 year **Limited Material Warranty** and may not be used within roof assemblies to receive a “Limited ‘Insured’ Warranty.”

UDL-40 is strictly for nailed underlayment use with shingles, tile applications and some metal roof applications. No printed warranty is available for UDL-40.

Limited “Insured” Roofing Warranties for 10 and 12 year periods are available for new construction, reroofing or recover projects using either BITEC modified systems or certain BITEC BUR-MOD systems.

struction, reroofing or recover projects using either BITEC modified systems or certain BITEC BUR-MOD systems.

Limited “Insured” Roofing Warranties for 15 and 20 years are only available for new construction and reroofing where the existing roof and insulation are completely removed down to the roof deck.

This will allow inspection and repairs to the existing deck providing essentially the same conditions as new construction. These warranties are available for BITEC modified systems or certain BITEC BUR-MOD systems.

Warranties for MINERAL DESIGN products are covered by a different material only warranty and depending on it's use may be covered by one of the **Limited “Insured” Roofing Warranties** because it is essentially an APM-4T or SPM-4H product with the MINERAL DESIGN pattern of granule surfacing applied in lieu of the solid colors. MINERAL DESIGN products are covered in other publications.

NDL, Full System and NDL/Full System Warranties are available

only on new construction or on reroof projects where the existing roof and insulation is completely removed down to the deck. Roof insulation may not be reused for these or 15 or 20 year roofs.

Contractors are responsible for insuring that proper substrate conditions are provided for the type of warranty being requested.

BITEC Limited “Insured” Roofing Warranties can only be obtained by submittal of a Warranty Request from a BITEC Authorized Applicator. This is for approval, BEFORE the project begins. The installation must be performed to BITEC published specifications, details and any addendum thereto.

Approval will be given provided all criteria for Warranty issuance has been met. BITEC requires “Authorized” applicators to carry proper insurance coverage to receive these warranties.

BITEC warranties are transferable only when approved by the Manager of Technical Services. BITEC should be notified before any property ownership changes. For additional information call the BITEC Technical Services Dept. at 800-535-8597.



GENERAL REQUIREMENTS

SECTION 1.00

HANDLING AND STORAGE

All BITEC modified bitumen products in roll form must be stored on end to prevent damage to roll ends and prevent roll flattening. Rolls stored on their sides will flatten and stick together, making them very difficult to apply.

All BITEC membranes have protective surfacings such as mineral granules, films, sand or talc which act as a release. Mineral surfaced products must be stored on end with the selvage edge up away from supporting surfaces. Rolls stored with the selvage edge down will be difficult to apply due to crushing of the selvage edge.

BITEC modified bitumen membranes must be stored under cover with adequate ventilation until immediately before use, away from weather and the elements. Should membrane be stored on the job site, covering of the pallets is essential. Covering must be done with a tarpaulin or similar covering. **(Black or clear coverings are not acceptable).**

It may become necessary to split the protective shrink-wrap bag covering the rolls to provide ventilation in order to reduce the possibility of rolls sticking. It is advisable to store all materials in a shaded area at the job site, even if provisions for covering and ventilation have been performed.

Should any roofing material become wet or damaged, these materials must not be used; they must be replaced.

During cold weather, we suggest that membrane be stored inside a warm location until immediately before use. This will help in the ease of application, and

reduce the potential of membrane coatings cracking during their handling and application.

BITEC recommends that rolls be applied only when ambient temperatures are above 40°F for all APP modified bitumen products, and 30°F for all SBS modified bitumen products.

Nevertheless, application of membranes may be done below the recommended minimums, but certain minimum precautions must be taken.

When application of membrane occurs at lower ambient temperatures, the following precautions must be followed:

1) Never throw rolls of membrane on the deck or storage surface. Sudden impact of the roll can cause cracking of the modified bitumen coating.

2) When torching, unroll the membrane slowly to ensure proper flow of the coating. **(Adjust amount of heat coming from propane torch accordingly.)**

3) When mopping membrane, care must be taken to ensure that the mopping asphalt is of proper temperature for bonding membrane to substrate. **See SECTION 1.04 on Asphalt Temperatures.**

4) Should difficulty in application arise after following these instructions, discontinue application until ambient temperature is above minimums stated above for the respective products. It is the Roofing Contractor's responsibility to make this decision.

BITEC recommends that palletized units of material be stacked **one-high**. Double stacking is not recommended. However, if space is limited, APP products can be double stacked provided that a minimum $\frac{3}{8}$ " plywood sheet separates the units to prevent damage.

Under no circumstance should you double stack SBS modified bitumen products.

All necessary precautions have been taken to insure that BITEC products leave the plant in good condition. BITEC, INC. will not be responsible for damage to products due to circumstances and events beyond our control; including damage in transit, storage at distributors or contractors warehouses or on jobsites.

SECTION 1.01

PHASING

The practice of 'phasing' is **not recommended by BITEC** under any circumstance. It is best to install the roofing system as one unit.

If precipitation occurs before completion of the roofing system being installed, the Roofing Contractor is responsible for sealing the unfinished roofing system in a way to provide protection from water, and not to interfere with the successful completion of its installation.

The deck and roofing system must be completely dry before work commences after precipitation or dew. Installing membrane over wet surfaces will void warranty or disallow its issuance. Roofing over wet surfaces is not a good roofing practice.

SECTION 1.02

ASPHALT

Store all asphalt in such a way as to prevent leakage, moisture or other contamination and/or deterioration of the carton.

BITEC will only allow the use of ASTM D312 Type III or Type IV hot asphalt for mop application.

SECTION 1.03

ASPHALT APPLICATION

BITEC specifies solid interply asphalt mopping application at a rate of 25 lbs. per 100 sq. ft. All moppings shall be continuous and uninterrupted so as not to allow felt to touch felt at any point.

BITEC will allow a variance in weight of asphalt application of +/- 15% (21 lbs. to 29 lbs.), provided application is uniform, as previously noted.

It is required that the asphalt be maintained at its proper temperature for the specific products at the point of application.

For application of insulation, G2 base sheets and fiberglass ply sheets, follow EVT asphalt temperature guidelines.

Consult the respective asphalt manufacturer for this information, which should be provided on each carton or by certificates with each load of bulk asphalt.

Information should include manufacturer's name, batch number, heating temperature, flash point (FP), finished blowing temperature (FBT) and **equiviscous temperature** (EVT).

For modified bitumen membrane application follow the temperature guidelines set forth in the following SECTION 1.04, ASPHALT TEMPERATURES.

Spot mopping attachment of fiberglass base sheet should be performed by placing 9" diameter circles 18" o.c. in all directions at a rate of 15 lbs. per 100 sq. ft.

This is best accomplished with a spot mopping machine, otherwise the application gets very erratic and in many instances may not produce a truly spot mopped environment with small ribbons of asphalt between spots.

This could cause blistering at locations where voids occur and trap moisture.

SECTION 1.04

ASPHALT TEMPERATURES

Asphalt chills rapidly once it leaves its container on the roof and hits any substrate. Therefore it is important to maintain the temperature as long as possible for proper application purposes.

This asphalt serves the two-fold purpose of providing not only the waterproofing layers between reinforcing plies in BUR-MOD systems, but it must also provide a high enough temperature to properly bond the different plies at their interface. For this purpose, EVT temperature is adequate.

Hot asphalt application of ASTM Type IV or Type VI fiberglass ply sheets and ASTM D 4601 (UL Type G2) fiberglass base sheets requires careful attention to EVT temperatures. This information is usually provided on each carton of asphalt or with paperwork on each load. EVT temperatures may vary with each load or batch of asphalt.

Proper bonding of the SBS modified bitumen membranes to one another or to other surfaces requires a higher temperature than used with fiberglass ply sheets and therefore published EVT temperatures are not usually high enough to provide the proper bonding required. Asphalt used with SBS membranes not only provides an additional layer of waterproofing but it must also provide the heat necessary to properly bond the SBS surface to another surface. This type of bonding is an "adhesive" method as compared to "heat welding" or "torching" which is a "cohesive" method.

Proper application of SBS modified bitumen membranes requires the use of asphalt at higher temperatures, typically around 450°F to 470°F at the point of application, with the asphalt application not preceding the roll more than four to six feet, depending on the ambi-

ent air temperature and wind conditions. The upper temperature range of asphalt cools much faster than the lower temperature range.

If the asphalt is not at the proper temperature at the point of application, the membrane may appear to be stuck, but not actually be bonded together properly and could release some time in the future.

Proper asphalt application may take days to completely cure so that it cannot be peeled apart. DO NOT TEST the application by peeling it apart for at least two days.

The following recommendations for using and heating mopping asphalt should be followed:

1) **Type III** - For slopes from dead level up to 1" in 12" (1:12)

Application temperatures:

- Fiberglass base sheet and ply sheets 390°F to 425°F
- SBS modified bitumen membranes 435°F to 470°F

2) **Type IV** - For slopes from dead level - up.

Application temperatures:

- Fiberglass base sheets and ply sheets 400°F to 475°F
- SBS modified bitumen membranes 445°F to 485°F

Machine application of asphalt may require higher temperatures, as much as 25 degrees. Consult asphalt manufacturer for this information.

Asphalt should not be heated above its Flash Point (FP). Heating above the Finished Blowing Temperature (FBT) should be closely monitored and only be done for short periods of time, not to exceed four (4) hours. Otherwise, the asphalt could experience "fallback" and/or become degraded.

Close attention to asphalt temperature is also of utmost importance to provide the proper quantity of asphalt between plies. Job conditions and equipment uses

often make it hard to operate within the proper temperature window. However, this does not relieve the contractor of the responsibility for proper application.

The quantity of asphalt per mopping is critical for several reasons. Too much asphalt can cause slippage, while too little will not provide an adequate waterproofing layer.

Also, too little will not carry enough heat and will chill faster, resulting in lack of proper fusion of interfacing surfaces. In addition to causing slippage, too much asphalt will cause the waterproofing layers to be less flexible which can cause cracking of the asphalt layer which in turn can cause splitting of the entire membrane system.

SECTION 1.05

CUT BACKS, EMULSIONS AND REFLECTIVE COATINGS

The use of "cut back" cement, coatings, plastic cement or adhesives is **prohibited** when installing any BITEC modified bitumen membrane.

Emulsions may be used provided emulsion manufacturer's application instructions are strictly adhered to.

Any reflective coating used as a surfacing over BITEC membranes shall be one that is approved by BITEC. For a list of currently approved coatings, contact BITEC's Technical Services Department for details.

Allow membrane to weather a minimum 45 days before surfacing is applied.

SECTION 1.06

CANTS

Cant strips are required on all roofing installations. Fire retardant cant strips are recommended.

SECTION 2.00

ROOF MEMBRANE INSTALLATION

BITEC modified bitumen roofing systems should be applied in accordance with BITEC specifications and construction details provided herein, or as may be approved in writing as special conditions arise. Installation should be done without **phasing**.

SECTION 2.01

TEMPORARY ROOFS

When conditions exist in the field prohibiting the total completion of the system, the designer, general contractor, building owner, architect and roofing contractor should consider the use of a temporary roof.

The temporary roof should consist of a minimum two (2) plies of **fiberglass base sheet**. Fiberglass ply sheets are unacceptable for use in temporary roofs. Type and number of plies will depend upon length of time involved before the **permanent** system is installed.

BITEC reserves the right to accept or reject the use of a temporary roof as a vapor retarder in the permanent roofing system.

SECTION 2.02

BASE SHEET FASTENING REQUIREMENTS

First ply of the BITEC roofing membrane system must consist of at least one (1) ply UL listed Type G2 fiberglass base sheet.

The base sheet should be installed with minimum 2" side and 4" end laps. Base sheet should be mechanically fastened to nailable substrates 9" o.c. along the 2" side lap, and 18" o.c. in two rows, staggered, 12" in from each edge with approved fasteners.

Non-nailable or insulated substrates also require the use of a UL Listed G2 fiberglass base sheet, either solid or spot mopped with asphalt as required by BITEC roofing system specifications.

The roofing contractor should install base sheet in such a way as to maintain 6" minimum offset of end and side laps of the base and BITEC finishing membranes.

The base sheet must be smooth, completely dry, well adhered and free of debris prior to application of the modified bitumen membrane.

SECTION 2.03

BITEC MODIFIED BITUMEN MEMBRANES

Over the base sheet install one (1) ply of BITEC modified bitumen membrane with the specified side laps and minimum 6" end laps. End laps should be diagonally staggered and offset a minimum 3' from the preceding membrane end lap. Application of the membrane and base sheet should begin at the low end of the roof.

Layers of successive base sheet and membrane should be applied perpendicular to the slope on roofs below 2:12 slope for APP (1:12 for SBS) and parallel to the slope for roofs greater than 2:12 (1:12 for SBS).

For either membrane, parallel application requires backnailing. See section 3.01.

Torch Application:

BITEC modified bitumen membranes having "T" as an ending, (such as APS-4T), and their related flashing rolls are **designed for torch application only**.

Procedure for installing these membranes is as follows:

- 1) Unroll the membrane completely and align properly.
- 2) Re-roll one end of the roll tightly, about half way, maintaining

proper alignment.

3) Torch apply the re-wound portion of the roll. Heat should be applied evenly across the face of the roll, and up the previously installed membrane's top surface (where the side lap is formed) in an "L" configuration. While heating, unroll the roll with uniform downward pressure. An indication that the torchable surface has reached the desired welding temperature is the observance of the film burn-off sheet melting, leaving a glossy surface of modified coating to be bonded to the substrate. If flow of modified coating is observed before contact with the substrate, the welding temperature is too great. Welding temperature is correct when flow from all seams is $\frac{1}{8}$ " to $\frac{1}{2}$ ". Too much flow indicates too much heat; while no flow indicates too little heat.

4) Rewind the balance of the roll and proceed as described above. End laps should be a minimum 6" in coverage and staggered a minimum 3' from the preceding course.

5) During end lap application, the underlying membrane's lower outside corner, at the end of the roll, should be trimmed. Then, follow with the overlapping membrane. This is also known as the "T" joint. Corners should be trimmed at an angle $5\frac{1}{2}$ " long from end of roll to outside edge. Width of trim should be 3" for products requiring 3" side laps, and 4" for those requiring 4" side laps. Succeeding courses should completely cover all trimmed edges. Apply trimmed rolls to provide a full 6" end lap.

6) BITEC does not recommend the use of mechanical torching wagons for application of membrane.

7) All end and side laps should be checked at the end of the work day for proper bonding. Areas not having the proper bond, or required flow from seam, should be repaired by gently lifting the lap with a pre-

heated round nose roofer's trowel, re-heating the area with a torch and applying pressure to the lap forcing the molten bitumen out. **Never attempt to repair laps by heating the top surface of the membrane.**

Hot Mopped Application:

BITEC modified bitumen membranes having "H" as an ending, (such as SPS-3H) are designed for application with hot asphalt. The roofing contractor must not allow mopping asphalt temperatures to fall below the recommended application temperature, for the particular asphalt, at the point of application. The roofing contractor must not overheat the asphalt to compensate for rapid cooling.

1) Over the installed fiberglass base sheet, install BITEC hot applied modified bitumen membranes in a continuous and uninterrupted mopping of specified asphalt. Moppings should be a minimum of 25 lbs. per 100 sq. ft. The mopping asphalt must be applied uniformly across the full width of the roll, including the selva edge of preceding layers.

2) A small amount of asphalt should extend beyond the end and side laps to ensure full bonding.

3) Correcting unbonded laps is the same as for torch applied products, using a preheated trowel.

Cold applied adhesives are prohibited for the purpose of repairing laps or seams. Plastic cement is prohibited for use with any BITEC modified bitumen membrane system.

BITEC DOES NOT RECOMMEND "FLYING-IN" OR "MOP AND FLOP" METHODS OF APPLICATION.

SECTION 2.04

FIRE-RATED MEMBRANES SFM-3.5H-FR, SFM-4H-FR

These membranes are polymer

modified waterproofing membranes, composed of carefully selected asphalts with superior modifying characteristics and blended with high-quality SBS rubber, reinforced with a high-strength fiberglass mat.

They are mineral surfaced and incorporate a smooth, even application of fine sand on the back surface to prevent blocking of rolls and to provide a smooth, acceptable application surface.

Special Formulation gives "FR" membranes a degree of fire resistance to effectively pass the UL Class "A" testing without the use of additional surfacings or protective coatings.

Systems require a minimum of one UL TYPE G2 fiberglass base sheet, such as BITEC Beta Base, for UL Class "A" rating, for both non-combustible and combustible decks.

These membranes can be applied by using hot asphalt or by using any BITEC approved elastomeric cold process adhesive. (When using cold adhesives, follow specific adhesive manufacturer's installation specifications.)

Refer to the most recent UL Roofing Materials & Systems Directory for fire classifications.

Packaging:

Palletized units contain 20 rolls of FR waterproofing membrane. Each unit is shrinkwrapped in a special polyethylene bag for stability and each pallet bears the UL Label. BITEC recommends that units of material be single stacked.

SECTION 2.05

BASE FLASHINGS

BITEC requires base flashings backed up by a fire retardant cant strip at all transitions from a flat roof to walls or curbs. Base flashings should be a minimum of 8" high, which has been an industry

standard for many years.

Metal Base Flashings are not acceptable.

Base flashings for all two-ply, 10 or 12 year systems should consist of at least one additional ply of the same material as the cap sheet membrane used. For wood wall or curb construction, an additional ply of base sheet is required also.

For multi-ply membrane systems, the base flashing must consist of at least an additional ply of both the interply membrane(s) and the cap sheet membranes being used.

Base flashings should be constructed with 6" vertical laps every 36" maximum. This makes the base flashings stronger and easier to install correctly.

If flashings are constructed with membranes installed parallel to the wall or curb surface, lengths of flashings should be cut to no longer than eight (8) feet.

Mop and flop installation of base flashings is not recommended. They should be either torched or mopped in place, or SBS flashings may be installed in SBS modified flashing mastic.

BITEC SPM-4.5T must be torch applied and may be used with any asphalt built up roof or BITEC SBS membrane.

BITEC does not issue a separate "flashing endorsement." On warranted projects, base flashings up to a maximum height of 24" are included in the warranty. Flashings over 24" high are considered wall flashings and are not covered by the membrane warranty for that project, unless specifically covered by a special agreement.

More information about flashing installation is available in the supplementary pocket size publication, "Flashing and Application Guide".

SECTION 2.06

CONSTRUCTION DETAILS

BITEC flashing rolls are specifically designed for use with full rolls of the same type. Flashing rolls come in 1/2 and 1/4 roll widths. Application is the same for flashing rolls as it is for full rolls of the same type.

Prior to flashing roll application, vertical concrete or masonry surfaces require preparation. Prepare these surfaces by applying asphalt primer, conforming to ASTM D41, at a rate of 1/2 gallon per 100 sq. ft.

Primer must completely dry before application of flashing membrane commences.

Wood surfaces should receive one ply fiberglass base sheet nailed 8" o.c. with capped nails.

All flashings should extend a minimum of 8" above the roof deck, and be nailed 8" o.c. with capped nails, along the top edge.

Pipe flashings, flashing pans and other metal flashings must have a minimum 4" continuous flange. All metal flanges must be cleaned to remove residual oils and lightly primed with asphalt primer, conforming to ASTM D41, prior to installation.

Primer must completely dry before application of flashing membrane commences. (See construction details 1 thru 32 on pages 32-53.)

SECTION 2.07

COATINGS AND SURFACINGS

It is considered a good roofing practice to coat all smooth surface roofing membranes.

With mineral surfaced membranes, protective coatings are not necessary unless it is required by code or through testing with inde-

pendent laboratories such as Underwriters Laboratories, Inc.

Refer to UL and FM publications to ensure system meets requirements as specified by code requirements. Roof coatings should be applied in two (2) even applications, except when specified otherwise by coating manufacturer.

BITEC SPS-3H will require a BITEC Approved Coating, or flood coat and gravel for UV protection. Roof coating should be maintained through the life of the system.

When design requirements call for additional surfacing to satisfy particular aesthetic or fire resistance properties, BITEC recommends the use of the following guidelines:

Gravel or Slag:

Surfacing should be opaque, clean, with moisture content of 2% or less and conform to ASTM 1863-93. Slag or gravel should be 1/4" to 5/8" in diameter applied in a flood coat of ASTM D312 Type III asphalt.

Asphalt flood coat should be applied at a rate of 60 lbs. per 100 sq. ft. Uniform application of flood coat is mandatory. Slag or gravel should be applied at a rate of 400 lbs. per 100 sq. ft., or as may be required for adequate coverage.

Consideration must be given to ensure that roof load does not exceed building's structural capacity.

Asphalt Emulsions:

Following surface preparation, apply one coat of asphalt emulsion to the entire membrane and vertical surfaces, at a rate of 3 gallons per square, unless otherwise indicated by the specific emulsion manufacturer's installation specifications.

Apply emulsion using a brush or spray applicator, brushing or spraying towards laps. **A minimum of 45 days must elapse before the emulsion is applied.**

Aluminum Coatings:

For best results, the BITEC approved reflective coating should be applied in two uniform applications. However, BITEC recommends that the specific coating manufacturer's installation procedures be strictly followed.

When considering UL Fire-Rated systems and products, consult the *UL Roofing Materials and Systems Directory* for individual system requirements.

A minimum of 45 days must elapse before the reflective coating is applied.

SECTION 3.00

NAILABLE SUBSTRATE DATA

It shall be the designer's responsibility, not BITEC, INC.'s responsibility, to consider wind conditions in the roofing projects' geographical area.

Current Factory Mutual Loss Prevention Data Sheets 1-7; 1-28; 1-28R; 1-29; 1-29R and 1-49, etc., give information and requirements on proper fasteners and methods of installation.

We recommend that the designer conduct jobsite fastener "pull-out" tests in order to determine the most suitable fastener for a specific application.

Responsibility rests with the designer, and not BITEC, for this determination, and for determining which fastener to use. Where nails are used as fasteners, they must be capped nails with either spiral or annular ring shanks. **Smooth shank nails are not acceptable.**

BITEC will not assume responsibility for failure or damage of the roof system resulting from either fastener or deck material failure, or assume any responsibility for their performance.

SECTION 3.01

STEEP SLOPE FASTENING REQUIREMENTS

BITEC membranes applied on slopes exceeding 2:12 for APP membranes and 1:12 for SBS membranes should be installed parallel to the slope and fastened as followed:

Nailable Substrates:

Base ply should be mechanically fastened as specified in selected BITEC roof system specifications. Install BITEC modified bitumen membrane as specified, blind nailing end laps 2" in from top edge and 6" o.c. with capped nails or other suitable fasteners.

Insulated Substrates:

Fiberglass base sheet should be applied to the insulation in accordance with insulation manufacturer's specifications provided it does not conflict with application statements set forth herein.

Base ply should be fastened to wood nailers or through the insulation to the deck, 8" o.c.. Installation of the modified bitumen membrane should proceed as specified, blind fastening end laps 2" in from top edge and 6" o.c. through suitable fasteners. Maintain 6" end lap seal beyond fastener plates.

SECTION 4.00

GENERAL DESIGN CRITERIA FOR ROOF DECKS

All substrates which are scheduled to receive BITEC modified bitumen membranes and roofing systems shall be **smooth, clean, completely dry and free of sharp projections and depressions.**

Roof decks shall be constructed in accordance with the deck manufacturer's specifications, or applicable industry practices, local codes,

and shall be designed to support live and dead loads, both during and after construction, without excessive deflection or movement between deck components.

Decks should also be designed and constructed to resist wind uplift forces anticipated in the area, and provide satisfactory base to which the roofing can be attached.

It is not the responsibility of BITEC to insure that the deck provides a proper substrate for the roof system.

All decks must be prepared for retrofit as specified herein, before application of BITEC products.

The responsibility for roof deck system design and roofing system selection, including vapor retarder, roof insulation and expansion joints, lies with the architect, engineer, owner and not with the roofing contractor or roofing materials manufacturer.

BITEC personnel are available for consultation regarding substrate surface over which the membrane is to be applied.

Care should be taken to set drains and outlets in the roof's expected or designed low areas with consideration to structural supports positioning and anticipated building settling.

Drain flanges shall be recessed flush to deck surfaces to provide positive drainage and prevent water damming at rims.

A minimum slope after construction of $\frac{1}{4}$ " in 12" ($\frac{1}{4}$:12) is recommended. **Roof deck shall provide positive drainage, with outlets installed to completely remove water within 72 hours after the rain stops.**

Installation of conduits or piping above the deck and under the roofing membrane is prohibited. Conduit or piping should be placed under the roof deck or above the completed roofing sys-

tem, properly supported and flashed to prevent damage to the roof system.

All openings and projections through the deck should be completed prior to installation of the roofing system. Acceptance of a roof deck to receive the BITEC modified bitumen membrane system refers **only to deck surface**.

When reroofing, all existing base flashing and metal flashings must be replaced for acceptance and potential issuance of a BITEC Warranty.

SECTION 4.01

EXPANSION JOINTS

Expansion joints should be installed along the entire length of the expansion joint, continuing fully to the roof deck edge or perimeter. Low profile, preformed elastic expansion joints with sheet metal flanges should not be installed on a flat roof deck.

These expansion joints should be installed by fully fastening to wood nailers placed on each side of the expansion joint, with accompanying tapered edge strips to provide smooth transition onto the field of the roof.

Conventional wood curb expansion joints should extend a minimum 8" above the roof surface.

Criteria which dictates the use of expansion joints are as follows:

1. Where the structural design and/or deck changes direction.
2. Where deck types change: steel deck to concrete deck, or light gauge steel on short spans to heavy gauge steel on long spans.
3. Where the design configuration creates separate wings, such as: "T", "L", or "U" configurations.
4. At building additions, canopies, and exposed overhangs.
5. At adjacent building sections that are kept at drastically different

temperatures.

6. In reroofing; at the obvious areas of stress concentrations which have caused splits in existing situations.

7. Drainage design factors.

Area dividers should not be considered as replacements for expansion joints. **The designer** should always consider the effects of expansion joints and area dividers on roof drainage as required.

The architect or engineer is responsible for determining location, number and type of required roof deck expansion joints and/or roof area dividers.

SECTION 4.02

VAPOR RETARDERS

A vapor retarder is not considered part of the roofing membrane. The decision to use a vapor retarder rests with the designer, architect or engineer, after careful consideration of design and environmental criteria, including relative interior humidity, interior temperature, type of construction, building occupancy and exterior cold weather temperature variables.

As a guide, vapor retarders are generally used where average January temperatures are 40°F or below and winter season interior humidity is 45% or greater. The temperature at the vapor retarder must be warmer than the dew point temperature to prevent condensation from occurring.

Constructions having insulated ceilings below the deck require special attention to design and dew point calculations.

If a vapor retarder is incorporated into a roof system, **one-way pressure release vents** should be installed at the rate of one (1) vent per 1000 sq. ft. of roof area to improve venting of water vapor which may become entrapped after the construction of the roof system.

Remove insulation from the area directly under the vent opening and refill with loose insulation prior to the vent placement and subsequent flashing.

The following **guidelines** are important to the satisfactory performance of the vapor retarder, and total roofing system:

1) Application techniques and all components of the vapor retarder used must be compatible with selected roofing system.

2) Vapor retarder should provide a permeability rating close to 0 perms.

3) Adequate adhesion properties, to meet design requirements for wind uplift resistance, must be provided by the vapor retarder; especially in the absence of mechanically fastened insulations.

4) Vapor retarders should be fully sealed at all end and side laps, securely flashed to roof top penetrations, and folded on top of roof insulation a minimum of 6" at the perimeters.

5) Designers of the roofing system should consult with Factory Mutual and Underwriters Laboratories for fire resistance and wind uplift ratings. BITEC, INC., expressly states that the company will not accept any responsibility for damage to, or failure of the roofing system caused by the use, or the absence of a vapor retarder.

Note: Fiberglass roof insulations should not be used as a venting strata over known wet or damp substrates; whether new construction, or retrofit.

Note: Items in systems which may require vapor retarders are:

- a) Lightweight insulating concrete
- b) Gypsum fills
- c) Wood decks
- d) Pressurized plenums
- e) Concrete

SECTION 4.03

PRESSURIZED PLENUMS

Consideration for a vapor retarder is necessary here. This will prevent induced vapor transmission through a vented substrate into the roof system.

SECTION 4.04

CONSTRUCTION DETAILS

Selection and design of roof top flashings is critical to the total roof system's performance as well as the flashings application. Vertical surfaces, metal and wood curbs, mechanical equipment platforms and supports, roof top accessories and other penetrations must be structurally sound, firmly attached and prepared to receive the BITEC modified bitumen membrane flashing system.

A pressure treated wood nailer, having a minimum width of 4½", should be installed at all eaves, gable ends, and deck openings in the roof for securement of the roofing membrane, roof fixtures and metal flashings. Wood nailers should be the same thickness when roof insulation and/or tapered edge strip is specified.

BITEC does not recommend the use of pre-formed metal curbs having horizontal metal flange of less than 4" in width when built into the roof membrane.

All metal roof flanges must be primed, both top and bottom, with an asphalt primer that conforms to ASTM D41 criteria. Primer must be allowed to dry thoroughly before installation. Roof flange must be securely fastened.

Mechanical equipment should be installed before application of the roofing membrane is performed to reduce the potential of damaging the membrane.

Roof edge metal flashings

should be installed in accordance with FM Loss Prevention Data Bulletin 1-49 as a minimum, for protection from wind damage or loss.

Base flashings should only be adhered to walls, curbs or nailers which are supported by the same structure as the roof membrane. Otherwise, differential movement between structures can cause splitting or deterioration of the membrane flashing.

Some base and penetration flashings shown in this manual are for 2-ply systems only. Other multiply systems require additional plies commensurate with system being installed. Refer to section 2.05.

SECTION 4.05

OTHER DESIGN CRITERIA

BITEC recommends that the roof installation be delayed until such time that all other trades have completed work which requires additional traffic across the deck or membrane.

Roofing contractors should monitor newly installed roofs for damage when it is known or suspected that other trades have performed work over completed roofs.

Specifiers, designers and contractors should consider the use of a temporary roof membrane when active traffic during roofing system installation is inevitable.

The installation of any type of mechanical equipment on the roof should be avoided whenever possible. However, when equipment is mounted on the roof, it should be mounted in accordance to NRCA designs, but not limited to those included in this manual.

Walkways

Whenever roof mounted equipment will require frequent traffic for inspection or servicing, an addi-

tional protective layer of BITEC mineral surface membrane is required. It should be installed so as to denote, a walkway and/or work area.

When walkway materials other than BITEC membrane are specified for use, an additional protective layer of BITEC membrane is also required. Other materials should not be loose laid or adhered to the BITEC main roof membrane.

Walkway materials should be installed in short sections not over 6' long with minimum 6" spaces to permit proper drainage.

BITEC recommends the use of a contrasting color for walkway materials to promote the use of the designated walkway to keep roof traffic to a minimum in unprotected areas.

When elevated walkways are installed on wood blocking or other materials, an additional protective ply of BITEC membrane must be used at each support location for the elevated walkway.

SECTION 5.00

ROOF DECKS

An acceptable roof deck surface is considered as being one which is clean and free of debris, smooth, completely dry and structurally sound. All penetrations, curbs, walls and other flashing details should be in place, ready to receive the roofing system before installation commences. Roof accessories should be available before the roofing contractor begins work.

SECTION 5.01

STEEL DECKS

Steel decks should be 22 gauge minimum, and comply with gauge and span requirements as set forth by deck manufacturer, and installed in accordance with all other industry standards and current *FM Loss*

Prevention Data Bulletin 1-28. Refer to FM 1-29 for minimum thickness requirements for various types of roof insulation. Refer to BITEC Insulation Section for proper attachment of insulation and roof membrane.

Steel deck side laps should be mechanically fastened with self tapping screws at mid-span between bar joists or supports. Spans exceeding 6' should receive two (2) fasteners at the side lap. End laps should be staggered to prevent buildup of side laps at corners, therefore preventing high spots over which insulations are to be laid.

All fasteners should be checked before installation of roofing membrane to ensure functionality. BITEC recommends use of non-corrosive fasteners approved by Factory Mutual, and/or the insulation manufacturer, when insulation is installed over steel decks. (Refer to "Fasteners" page 31.)

All steel decks should be covered with a mechanically fastened, acceptable roof insulation board.

SECTION 5.02

POURED STRUCTURAL CONCRETE

All surfaces shall be smooth and visibly dry. Wood nailers shall be installed into the deck to provide for securement of the roofing membrane flashings at perimeters, penetrations and other deck openings.

The deck is then prepared by priming with an asphalt primer conforming to ASTM D41 criteria, which is allowed to **completely** dry before application of the roofing system insulation or fiberglass base sheet.

BITEC does not allow single ply modified bitumen membrane application directly over concrete decks. Fiberglass base sheet should be installed to the concrete deck by

mechanical attachment, spot mopping or strip mopping. **Fully adhering base sheet to the concrete deck is prohibited.**

One way vents are required over all concrete type decks.

SECTION 5.03

PRE-STRESSED OR "T" SECTIONS

Set or camber should not allow ponding of water. Offsets between units should not exceed $\frac{1}{8}$ ". **Surfaces which are uneven are deemed unacceptable.** Suitable fill should be given to all uneven fits, and sections leveled before roofing system is applied.

A leveling course of roof insulation should be installed prior to application of membrane system. To prevent bitumen drippage, deck joints must be taped prior to application of roofing system. Refer to Insulation Section for proper attachment of insulation and roofing membrane.

SECTION 5.04

LIGHTWEIGHT INSULATING CONCRETE

Caution - This deck contains a large percentage of moisture, therefore adequate precautions must be taken to avoid any entrapment of moisture under the roof system.

The following guidelines are recommended by BITEC concerning the lightweight insulating concrete deck acceptance before installing membrane:

- 1) Decks having a density of less than 22 lbs. PCF, 1:6 mixture (min. compressive strength of 125 psi) are unacceptable.
- 2) A minimum of 2" top surfacing fill is recommended.
- 3) Deck **must** provide a minimum 40 lbs. withdrawal resistance

for the selected approved mechanical fastener at the time the roofing system is installed. It is the responsibility of the roofing contractor, architect or engineer to request and review testing for fastener withdrawal strength. BITEC merely recommends withdrawal tests be done; it's good roofing practice.

4) During curing or application, the deck must not be subjected to temperatures below 40° F. **Frozen decks must be replaced.**

5) Drying time shall be as per deck manufacturer's specifications.

6) Lower moisture, quick drying lightweight fills may require less drying time.

7) Surface must be smooth, visibly dry, free of debris, sharp projections and depressions.

DECK MANUFACTURER AND AUTHORIZED APPLICATOR MUST PROVIDE ALL PARTIES CONCERNED WITH A LETTER OF CERTIFICATION STATING THE DECK IS READY TO RECEIVE ROOFING SYSTEM AND THAT DECK COMPLIES WITH THE ABOVE MINIMUM REQUIREMENTS.

After installation of the roofing system, the General Contractor should provide ventilation to prevent interior moisture from infiltrating the deck during construction, until occupancy by owner.

Additional Insulation

When additional insulation is to be installed over lightweight decks, a UL Type G2 or G3 fiberglass base sheet must be mechanically fastened to the deck. **BITEC does not recommend direct attachment of roof insulation boards to this type of deck.** Additional insulation may be hot mopped to the fastened fiberglass base sheet.

Installation of the Roofing System

Fiberglass base sheet should be

installed with mechanical fasteners **only**, over this nailable substrate. Fasteners must be of a type and size approved by BITEC, and the deck manufacturer. Refer to FM publications for type and installations requirements in order to obtain proper wind uplift resistance requirements.

Pressure Relief Vents

A 4" minimum diameter pressure relief vent, with 4" minimum flanges and weather resistant hood, shall be installed 20 ft. in from perimeter edges. **Pressure relief vents must be of a one-way design.** Thereafter, pressure relief vents shall be installed 30 ft. o.c. located directly over 4" diameter openings cut through the roof system and down to insulating fill.

Caution: Insulating concrete fills over existing roofs, concrete decks or decks without venting are not acceptable. Lightweight deck fills installed incorporating the use of Insulperm or other EPS insulations full of holes and using the new low moisture content deck mixes over unvented steel decks or concrete decks will qualify as a deck suitable for installing a BITEC membrane to be warranted. BITEC does not recommend installing these decks over existing roof membranes.

BITEC will not accept any responsibility for damage or failure of the roofing system caused in any way by the lightweight insulating concrete deck or fill, or failure to follow instructions set forth within this publication.

SECTION 5.05

WOOD PLANK DECKS

On wood decks, to prevent bitumen drippage, install dry sheathing paper. A nominal thickness of 1" is required for the wood planks. Knotholes shall be covered with mechanically fastened sheet metal.

SECTION 5.06

PLYWOOD DECKS

Plywood decks should have a nominal thickness of ½" and be a min. 4-ply plywood, APA marked, exterior grade.

All four sides of each piece should bear on and be securely nailed, or fastened to joist and cross blocking. In the absence of cross blocking, two-ply clips per 24" max. joist spacing, should be used.

Only wolmanized lumber shall be used for blocking. **The use of petroleum treated lumber is strictly prohibited.**

A divorcing layer of rosin paper or sheathing paper is optional. One ply of UL Type G2 fiberglass base sheet is required to be secured by mechanical fasteners.

BITEC will not be responsible in any way for damage to the roofing system should this deck fail.

NOTE: For warranty periods beyond 10 years, a minimal layer of ½" insulation may be required.

SECTION 5.07

POURED GYPSUM DECKS

To accommodate approved fasteners used to attach base ply or insulation to this type of deck, refer to Factory Mutual publications for specific fastener and fastener applicability.

Do not apply any roofing system by adhesion with hot asphalt, cold applied adhesives or by heat welding to this type of deck.

Deck surface must be smooth, clean and visibly dry, free of projections and free of depressions.

Poured Gypsum decks require one-way vents.

SECTION 5.08

STRUCTURAL WOOD FIBER DECKS

Before roofing system application on this type of deck, the deck must be in proper condition.

Where elevation of deck joints vary, the deck erector must level the joints with screed coat material as recommended by deck manufacturer.

The deck erector must furnish written certification that the deck meets job specification and deck manufacturer's requirements.

Each joint or tongue and groove, should be stripped according to the following steps:

Apply a bead of plastic cement over the joint, then cover the joint with a 6" wide strip of fiberglass base sheet, centered over the joint and adhered to the plastic cement.

Apply fiberglass base sheet in lengths not to exceed 18', with 2" side laps, and 4" end laps, end laps not less than 3' apart, diagonally staggered.

Mechanically attach fiberglass base sheet 9" o.c. along the 2" side lap; 18" o.c. in two staggered rows 12" in from both sides.

A layer of roof insulation over this base sheet is required. Then, install the membrane system as specified.

BITEC assumes no responsibility for failure of the roofing system or damage caused in any way by structural wood fiber decks, or failure to follow instructions set forth herein.

SECTION 5.09

OPEN BEAM CEILINGS

Over open-beam ceilings, the insulation shall be covered with ½" thick mechanically attached plywood.

SECTION 5.10

WOOD NAILERS

Pressure treated wood nailers of 4½" minimum width should be installed by others at all eaves, gable ends and openings in the roof for securing of roof plies, gravel stops, edging and roof fixtures. **The use of petroleum treated lumber is strictly prohibited.**

Solid wood blocking of treated lumber is required for all insulation stops, metal edge flashings, and all other metal flanges built into the roof membrane.

SECTION 6.00

REROOFING PREPARATION AND FIELD CONDITIONS

The following requirements shall be used in conjunction with good roofing practices to qualify the assembly for issuance of any BITEC workmanship and material warranty:

1) Test cuts shall always be taken from an existing roof system for determination of deck type and vapor retarder, insulation type, condition and attachment; number of membranes installed, their type and condition; and for presence of moisture within the system.

2) Deck shall be **completely dry** and structurally sound.

3) Parapet walls, perimeter edges, equipment or other load bearing supports, platforms, curbs, etc., shall be structurally sound.

4) Additional weight of selected roof systems shall not exceed safe load design.

5) Existing plywood decking not having continuous solid end blocking, and decking less than nominal ½" thick, is not an acceptable deck. Depending on deck rigidity, an additional layer of roof insulation may be required.

6) Surface to receive new roofing system shall provide for **positive drainage**.

7) Existing roof insulation shall be **dry** and firmly attached.

8) Existing roof system shall be **compatible** with the new roofing system.

9) Existing membrane shall be completely dry, clean and free of debris, with all surface defects repaired.

10) Existing roof system with aggregate surfacing should be torn off. When gravel is removed for recovering, a mechanically attached ½" min. thickness recover board shall be installed.

11) Replace all existing metal flashings which build into the roof membrane.

12) All existing metal counter-flashing or coping should be replaced **to match existing**, as a condition of Warranty compliance.

13) Expose entire metal flange of all drains. Sheet metal drains unsuitable for reuse shall be removed and replaced **to match existing**. Clean and save clamp rings for re-use; broken clamp rings must be replaced. Stripped or broken bolt holes shall be drilled and retapped.

14) Abandoned equipment shall be removed and decking required shall be installed **to match existing decking**.

15) Height and/or clearance of flashings at membrane terminations shall be in accordance with construction details.

16) Base and wall flashings shall be removed when loose, or with insufficient clearance under counterflashing to receive new roof system.

17) All roof penetrations should have metal flashings.

18) Joints in masonry copings should be recaulked and/or re-grouted as needed.

19) Equipment vibration must be corrected.

20) Membrane to receive wood blocking pipe support shall be reinforced with an additional ply of modified bitumen membrane, identical to the membrane used as the cap sheet.

21) Condensate lines shall extend to the drains.

22) **BITEC recommends that when retrofitting any existing coal tar pitch roof, a divorcing or separation layer of either plywood or insulation of ½" minimum thickness be installed over the existing roof prior to application of fiberglass base sheet and finishing membrane.**

WARNING: coal tar pitch is not compatible with any BITEC modified bitumen membrane.

23) The divorcing layer shall be mechanically attached. Refer to FM publications for mechanical attachment to meet FM wind uplift requirements.

Since all field conditions cannot be covered in this specification book, and due to the complexity of preparing reroofing specifications, BITEC offers assistance in specification selection and preparation.

Reroofing projects may qualify for Warranty when all installation and procedural criteria are met.

NOTE: SUBSTRATES WITH TWO (2) OR MORE ROOFS ARE NOT ELIGIBLE FOR CERTAIN WARRANTIES.

SECTION 6.01

ADDITIONAL PRECAUTIONS

Existing roof surface - Over an existing roof surface proper preparation of the surface is essential. Blisters, splits, undulations, etc., must be repaired in accordance with **good roofing practices**.

Note: Direct application of any BITEC waterproofing membrane

to the existing deck or membrane is **not recommended**.

Defects in the existing roof system such as cracks, crazing, deteriorated bitumen, and moisture can cause failure or damage to the membrane system. Conditions arising from the above will result in nullification of the Warranty.

All existing metal flashing must be replaced if existing metal is found to be damaged or deteriorating. Metal flashings must be primed with an asphalt primer, conforming to ASTM D41 criteria, before membrane is applied.

SECTION 6.02

INSULATION

Insulation used in re-roofing any existing system must be installed in accordance with the insulation manufacturer's guidelines for the specific insulation used. BITEC **does not** consider any roof insulation as being a part of the membrane system and will not warranty the same.

Most forms of insulation are compatible with BITEC membrane systems, however, a prefaced insulation is recommended. Insulation must be installed with hot asphalt and/or mechanically fastened according to the insulation manufacturer's guidelines.

BITEC reserves the right to accept or reject any form of roof insulation as a suitable substrate for the attachment of BITEC membranes.

Performance of any manufacturer's insulation is not warranted by BITEC, nor will BITEC accept responsibility for failures or damages to the roof system or membrane caused by the specific insulation used.

Complete removal of spray urethane foam is required before installation of any BITEC roofing membrane system.

BITEC waterproofing membranes installed over low melt point, or high heat sensitive insulation (i.e. polystyrene) require a divorcing layer of ½" minimum perlite insulation. The divorcing layer **must** be mechanically attached through the heat sensitive insulation, followed by the installation of a UL Type G2 fiberglass base sheet, hot applied. See Section 6.05.

Note: If at all possible, it is recommended that a Type G2 fiberglass base sheet be installed with hot asphalt to an insulation/divorcing layer that has been mechanically attached. Metal stress plates become extremely hot during the torching process, and can harm the polyester core of the modified bitumen membrane. **Plastic stress plates are not recommended for use with torch applied products.**

SECTION 6.03

ROOF INSULATION, DOUBLE LAYER APPLICATION

BITEC strongly recommends double layer application of roof insulation, where design of FM specifications require mechanical attachment of the first layer, to reduce membrane stress and thermal loss at insulation joints and prevent thermal bridging between mechanical fasteners and the roofing membrane.

When using rigid urethane or polyisocyanurate insulations, where the first layer is mechanically attached with fasteners containing metal stress plates, BITEC recommends the application of insulation be in double layers.

SECTION 6.04

ROOF INSULATION, MECHANICAL ATTACHMENT

When design requirements call for mechanically fastening roof insulation, the architect, engineer,

owner, or roofing contractor should consult the insulation manufacturer and/or FM regarding the proper number, size, spacing and type of FM Approved Fasteners.

BITEC recommends the following minimum number of fasteners for each board size:

2' x 4' – 4 fasteners

3' x 4' – 6 fasteners

4' x 4' – 9 fasteners

4' x 8' – 15 fasteners

First layer of insulation should be mechanically attached, and the second layer, where applicable, installed in asphalt with all joints staggered and offset from the preceding layer.

Consult the FM publications for approved fasteners and fastener patterns for wind uplift requirements in the project's geographical area.

SECTION 6.05

INSULATION & ROOF SYSTEM APPLICATION

A UL Listed G2, fiberglass base sheet **must** be installed over insulated assemblies in accordance with the following guidelines:

Urethane and Polyisocyanurate Insulations

A divorcing layer of wood fiber, perlite or fiberglass roof insulation shall be installed prior to the application of the BUR-MOD or modified bitumen roof membrane system.

Follow specifications for application of the BUR-MOD or modified bitumen membrane system over the above divorcing layer.

A separation layer is required over all rigid foam insulation. Blistering can result if base sheet or membrane is directly adhered to this type of insulation.

Perlite, Wood Fiber or Fiberglass

Install these insulations by mechanical attachment or by appli-

cation in hot asphalt.

Install fiberglass base sheet in hot asphalt before commencing the modified bitumen membrane application.

Half inch (1/2") perlite insulation should not be encapsulated in hot asphalt.

When 1/2" wood fiber insulation is to be encapsulated in hot asphalt, **only high density wood fiber should be used.**

Expanded - Extruded Polystyrene (EPS)

Requires a divorcing layer of 1/2" minimum thickness of high density wood fiber or 3/4" minimum perlite insulation. All joints shall be taped.

Half inch (1/2") perlite may be mechanically fastened over these insulations. Fiberglass base sheet shall be installed in hot asphalt, fully mopped.

Consult insulation manufacturer for specific application instructions and restrictions.

SECTION 6.06

BASE SHEET REQUIREMENTS (ASTM D 4601, Type II)

BITEC recommends the use of a UL-Listed, Type G2 fiberglass base sheet, or a BITEC **COMPA-BASE** modified bitumen base sheet in all systems using BITEC cap sheet membranes.

Please consult **Section 2.02** for base sheet fastening pattern where FM requirements are not used.

Over insulated or non-nailable prepared, primed existing membrane, spot mop an approved venting base sheet or inverted UL G3 fiberglass cap sheet (buffer sheet) with ASTM D312 Type III asphalt. Never fully adhere buffer sheet to the existing membrane.

BETA BASE is required on all systems for 15 and 20-year, NDL and Full System warranties.

SECTION 6.07

UL LISTINGS

BITEC maintains an extensive listing of UL approved roofing assemblies, which is continually being updated and is published annually in the "*UL Roofing Materials and Systems Directory*".

BITEC also participates in UL's follow-up program and labels each pallet of product.

For specific UL Classification information, contact our Technical Services Department.

SECTION 6.08

FM SYSTEMS APPROVAL

Reroofing applications requiring assemblies that are FM Approved, using BITEC waterproofing membranes, can be found within FM publication, *Approval Guide*. Information concerning these assemblies can also be obtained through the BITEC Technical Services Department, or by calling your local representative.

SECTION 7.00

RE-ROOFING (RETROFIT)

It is the responsibility of the architect, engineer, and owner's representative to determine whether an existing roof is structurally sound, firmly attached, dry and suitable for recover. **Complete examination** is required to determine what repairs, if any, are necessary to effectively prepare the deck for re-roofing.

All wet insulation, defective materials and areas not suitable for application of the retrofit roof system must be repaired or replaced.

BITEC accepts no responsibility for failure of the roof system due to improper preparation

of deck prior to reroofing (retrofitting), or subsequent damages caused thereof.

SECTION 7.01

RE-ROOFING SPECIFICATION RGS-01 Over Gravel Surfaces

Procedure:

These BITEC General Requirements and any supplement thereto are considered part of this procedure and specification, and must be followed.

Application:

Before application of membrane begins, consult **Section 8.00** "Application Safety". Do not begin application of membrane until you have fully read and completely understand all procedures and precautions detailed.

1) All gravel must be removed by spudding, power brooming and vacuuming.

2) Follow with application of recovery board (divorcing layer) insulation, mechanically fastened, according to insulation manufacturer's recommendations, over the existing roof. Hot apply, or mechanically attach the UL Type G2 fiberglass base sheet over the insulation.

3) Install BITEC modified bitumen membrane as specified.

Coating:

Any roof coatings used with BITEC waterproofing membranes must be those which have been approved by BITEC's Technical Services Department.

Roof coating must be applied in accordance with the coating manufacturer's application instructions.

BITEC does not warranty roof coating, nor does BITEC warranty any failure of the roof membrane or system arising from either substance or application of the roof coating.

SECTION 7.02

REROOFING SPECIFICATION RSS-02 Over Smooth Surfaces

For reroofing over existing smooth surfaces, contact BITEC Technical Services Department.

SECTION 7.03

STATEMENT OF ACCEPTANCE

In order for warranty to be in effect when recover situations are called for, BITEC must be contacted for instructions.

Reroofing scenarios vary considerably from project to project. BITEC recommends that the roofing contractor consult the BITEC Technical Services Department for details and approval before starting any re-roofing project.

Failure to do so can prevent issuance of Warranty.

SECTION 7.04

PRESSURE RELIEF VENTS

BITEC requires one-way pressure relief vents on all recover situations whether or not a Retrofit Board or other recover or overlay insulation of any type is used.

These vents are also required over all types of concrete decks, insulating fills of all types and various combinations of both, for new or existing construction.

BITEC will not issue warranties for new wet fill decks installed over existing roof assemblies or any type of concrete decks or other non-vented decks.

One-way vents are required to relieve at least some of the below membrane pressure.

This pressure may develop from degassing of foamed plastic type

insulations or trapped vapor pressure created by moisture from any source heated by the membrane installation, interior heat drive or by solar energy. These vents are not intended to dry out wet situations.

BITEC recommends the use of spun aluminum vents with one-way valves. Flanges of these units must be primed, top and bottom, and dry before installation.

Installation should be done in accordance with Detail #29 of this book or other methods approved by BITEC.

Metal vents are recommended and preferred, however plastic type vents may be acceptable depending on project conditions. **Plastic type vents are not acceptable with torch applied membranes.**

BITEC will not accept any responsibility for damage or failure of the roofing system caused in any way by the omission of or use of vents on recover situations.

SECTION 8.00

APPLICATION SAFETY

Modified bitumen roofing membranes represent the latest in the evolution of bituminous roofing and waterproofing systems. Their ease of application and strength characteristics make them an excellent choice for waterproofing commercial and industrial roofs.

However, most systems require the use of hot asphalt or open flame propane torches to adhere the membrane.

Whenever working with an open flame, applicators must always use extreme caution to prevent accidents from happening.

Improper and/or unsafe application of waterproofing membranes can result in severe burns, physical injury, property damage and loss of property or life.

Your complete understanding of application safety is essential to the successful completion of any waterproofing project.

SECTION 8.01

PERSONNEL

Proper clothing should be worn while applying membrane. Long sleeve shirt, long pants, leather or durable shoes with **flat soles** and gloves.

Workmen, other than the torch operator, should be no closer than three feet from open flame.

SECTION 8.02

FIRE PREVENTION

It is the Contractor's responsibility to observe all fire prevention policies and practices; to train, instruct and warn employees on the use of torch equipment, and any other equipment used in the application of membrane systems.

Follow OSHA and NRCA provisions for fire protection, including, but not limited to those listed in OSHA 1910.151, 155, 156, 157 and 1910.110 which apply to torch application.

The Contractor should be familiar with NFPA 58 "Standard for the Storage and Handling of Liquefied Petroleum Gas", and any other appropriate publications of the National LP Gas Association.

SECTION 8.03

CODE AUTHORITY

The Contractor should be familiar with all local codes and design guides affecting his service area and should obtain any permits necessary before work commences.

In some areas, torch application is prohibited by local and/or state regulations.

SECTION 8.04

EQUIPMENT DO'S

- Do use an adjustable pilot with complete shut off valve.
- Do use a torch stand to direct flame upwards when not in use.
- Do use an adjustable, UL Listed, regulator with the torch.
- Do be sure that the torching equipment is in proper working order at all times.
- Do keep propane tanks in an upright position at least 10' from open flame.
- Do check all torching equipment for wear and tear. Replace or renew all worn or faulty equipment.
- Do use soap solution to check for gas leaks before lighting.
- Do use a pressure gauge on every regulator.
- Do have an ABC dry fire extinguisher on hand at all times while torching. One extinguisher per torch.
- Do stop work if the scent of unburned propane is detected. Make necessary repairs.
- Do close the propane cylinder valve first, and allow the residual propane to burn before closing the torch valve.
- Do instruct all workers on proper method of using fire extinguisher.
- Do use well built products having safety features, and that are listed by UL or FM.
- Do keep vent pressure regulator clear at all times.
- Do work safely at all times.
- Do ignite torch with flint or electric lighter. Matches or butane lighters are unsafe substitutes.
- Do treat a torch as if it is **always burning**.

NEVER LEAVE A TORCH UNATTENDED

SECTION 8.05

EQUIPMENT DON'TS

- Don't use more than 50' of hose at one time.
- Don't use an adjustable regulator with higher pressure range than that which came with the torch.
- Don't operate any pressure gauge beyond the top of its scale, or near excessive heat (150°F) or where there is vibration.
- Don't use equipment without an operating pressure gauge.
- Don't turn a vapor cylinder on its side to increase pressure. LP Gas can escape.
- Don't put out a cylinder fire if it cannot be done without tipping the cylinder. Let it burn, and call the fire department immediately.
- Don't use a cigarette lighter or matches to test for leaks.
- Don't keep fire extinguisher next to LP tank. If fire starts at tank, you may not be able to get to the extinguisher!
- Don't fill cylinders that are in need of repair.
- Don't use a trowel or other tools as a torch stand.
- Don't play with the torch.
- Don't use damaged or faulty equipment.

WHEN IN DOUBT... DON'T USE!

SECTION 8.06

BUILDING DO'S

- Do use perlite or non-combustible cant strips.
- Do use fiberglass base sheet on plywood decks and on cant strips.
- Do use tight fitting felt collar on all penetrations and metal flashings before torching.
- At the completion of each day's work, walk the jobsite

for at least one (1) hour after the last torch is put out, to check for smoldering fire.

- Do use a small torch when flashing near details.
- Do heat roofing away from air conditioning units, fans, soil pipes and all other protrusions - set in place while hot. Care must be taken to prevent flame from entering or being pulled down into the building interior.
- Do use fiberglass base sheet on all torching applications, over all substrates.

SECTION 8.07

BUILDING DON'TS

- Don't torch anything that you cannot see.
- Don't torch over combustible cants or to wood fiber insulation.
- Don't torch near gas lines, electrical wires or flammable vents.
- Don't point the torch under roof top equipment.
- Don't point torch into open roof top penetrations.
- Don't use a torch to dry out roof surfaces or as a pre-heater torch.
- Don't torch in an enclosed area.
- Don't lay operating torch on an open penetration on the roof surface. Flame can be sucked into the opening.
- Don't lay torch on the roof surface or membrane.

WORK SAFELY BY WORKING SMART!

ROOF INSPECTIONS & MAINTENANCE

All roofs, no matter what their composition, need periodic inspections to insure that they have not been damaged by accident or weather. The following industry accepted guidelines should be implemented to protect and maintain a roof for its maximum life and and trouble-free durability.

1) Restrict roof traffic to only what is necessary and to a minimum; keep a log of everyone going on the roof. Inform necessary trades requiring access to be very careful to protect the roof membrane from falling objects or solvent spills. Have a responsible person check the roof area when others have been working on the roof.

Keep records of the original roof installation dates, all products installed, repairs, the contractors' names, and any other rooftop activity. These records can be an invaluable aid in finding leaks at later dates and historical records will help determine the leak history for future repairs and replacements. You should file these records in a readily accessible place.

2) Do not allow materials or equipment to be stored on the roof. Roofs should not be allowed to become a junk yard for discarded equipment, empty cans, etc.

3) When equipment or materials must be transported over the roof, protect the affected area with plywood runways.

4) If roof membrane was surfaced with a reflective coating, a periodic recoating will protect the membrane and reduce energy costs.

5) Provide roof inspections at least twice a year. The more often a roof is inspected, the more likely that any problems will be discovered before they cause extensive damage. Some roofs will inherently require inspections more often to

insure that drains, scuppers and gutters are kept clear and open for maximum drainage. Additional inspections should be made after any major storms or when conditions may have allowed the roof to be affected. Discuss the possibility of an inspection and maintenance program with your roofing contractor, general contractor or roof consultant.

Other items to check for damage or necessary maintenance are as follows:

- a. Roof penetrations: Pitch pans need to be kept full and should have protective rain collars where possible. Where rain collars are not possible, the filler should be coated with an aluminum or other suitable coating. Use only durable filler products compatible with the original filler.
- b. Metal flashing joints will require periodic replacement of sealant and fasteners may need replacement or tightening. Joints at gravel guards and fascias built into the roof membrane are a particularly troublesome detail which generally need periodic maintenance.
- c. Reglets along walls, parapets or equipment, will need periodic replacement of sealant and fasteners may need replacement or tightening.
- d. Roof drain clamp rings may need periodic tightening.
- e. Base flashing may become loose from fastenings at top and/or corners and need repair. At parapets and some walls, base flashings are generally subject to differential movement which causes diagonal wrinkling and in turn can cause damage to the base flashing.
- f. Termination bars or compression fittings must be kept

securely fastened and any associated sealants must be kept in good condition.

- g. All roof membrane seams should be inspected for open seams, fishmouths, wrinkles, etc.
- h. All roof areas should be inspected for blisters, splits, loose areas, ponding water and debris accumulation.
- i. Expansion joints and control joints should be inspected for open joints, splits and loose fastenings.

6) Roofs that are under warranty by either a specific contractor or BITEC should not be repaired or altered by another contractor without express permission from that contractor and only BITEC's authorized contractors should perform work on roofs covered by BITEC warranties. Otherwise warranty coverages will be effected.

7) When roofs are to be altered by the addition of any roof top equipment or penetrations, the original installer and/or membrane manufacturer should be consulted first to insure that only proper materials are used for compatibility. Complete information regarding alterations or repairs should be kept on file and provided to the manufacturer of record.

8) Any apparent damage to the roof should be reported whether or not any leaks have been noticed. Repairs should be made promptly.

As a reminder, all additions of equipment, deck penetrations or any change requiring cutting through the BITEC membrane and any change which may alter the proper drainage of the roof must have prior approval of BITEC, INC. and the work must be completed by a BITEC Authorized Roofing Contractor to maintain the validity of the Warranty.

FASTENERS

Due to a changing fastener market, all reference to fasteners in BITEC publications will be generic and will only make reference to certain types and only appropriate designs for the specific deck or situation in which they are to be used.

Insulation and fastener manufacturers spend a great deal of time, effort and expense with FM and UL performing wind uplift tests. This testing is a continuing process and the best source of information will come from the manufacturers who are involved in the testing. Specific information is available from any of these manufacturers showing the exact fastening pat-

tern and type to be used.

BITEC merely requires that fasteners be of an "approved type, appropriate for the specific situation." BITEC does not specify any brand of fasteners but may recommend a type for a particular application. On the other hand, BITEC may elect not to approve a certain fastener for any reason.

For instance, BITEC does not approve the use of nails for securing insulation over 1/2" in thickness and in many instances will require the use of screw and plate type fasteners.

Fasteners used to secure mem-

brane end laps on slopes that require the membrane to be installed parallel to the slope, must always be screw and plate design, not nails, except for use in decks where a special type fastener is required. In some instances, even that special type fastener must incorporate the use of a larger stress plate.

Since BITEC does not manufacture, market or distribute fasteners, BITEC warranties do not cover fasteners. Any questions regarding fasteners should be directed to our Technical Services Department at (800) 535-8597.

FASTENERS

SIMPLEX NAIL & MFG.

"TUBE LOC" Nail. Base ply fastener. Nail insert. One piece tube with attached disc.

Nail locked in deck. 15/16" dia. cap; 3" dia. disc available.

Lengths:
1"
1-3/4"
2-1/2"
3"
4-1/2"
5-1/2"
6-1/2"

POWER FASTENERS, INC.

SPIKE

"WOODIE"

RAWL DECK SCREW. Sizes #12, #14.

"NAILIN" ZAMAC OR NYON

RAWL "SPEED LOCK" TOGGLE

Plastic

Galvalume Steel Plate

S.S. Sealing Washer

"POWERLITE"

ITW BUILDDEX

"ROOFGRIP" Self-tapping, self-drilling screw with steel or plastic plate.

GALVALUME

"POLYMER GYPTEC"

OLYMPIC FASTENERS

Round Washer Plates used with steel deck screws, Toggles and "Tectum" screws.

Steel 3S

Plastic 3P

"CONTITE"

"Non Thermal Bridging" Fastener. Lightweight Concrete and Cement Fiber.

NTB-2HWW Fastener with Locking Wire Barbs

"N-C FASTENER"

NTB-1HWO Fastener without Locking Wire Barbs

CONSTRUCTION FASTENERS

DEKFAST PLATES:

Steel Round

Steel Hexagonal

Plastic Locking

Stainless Steel Fastener

Deckfast #12

#15 High Strength

"DEKCLITE"

"Dekfast-14" - use same plates as with Dekfast-12

ES PRODUCTS INC.

"NAIL-TITE"

ES-60

ES-90

BUILDING MATERIALS CORP. OF AMERICA

"LEXSUCO" Universal plate and clip

Lengths Available:
Short 2-3/8"
Long 3-5/8"
X-Long 4-5/8"

TRU-FAST

TP Screw

DP Screw

CF Screw

2" Metal Plate

3" Metal Plate

CONSTRUCTION DETAILS

The following construction details are provided as minimum flashing detail guidelines for use with BITEC membranes. Specific field conditions may necessitate other details or modifications of these details. BITEC does not intend that details be limited to the ones shown in this manual.

Interruptions in the roof membrane are the most likely place for leaks to occur. Membranes should be installed in accordance with time proven methods and details.

Ultimately, the responsibility for the design of the actual specific details for any given project is the responsibility of the project de-

signer, be that an architect, engineer, consultant, owner or roof membrane installer.

However, for projects requiring a warranty with unusual conditions, consult BITEC's Technical Services Department regarding such conditions.

BITEC requires that good roofing practices, such as but not limited to those published in the *NRCA Roofing and Waterproofing Manual*, be followed with all installations. These details have been developed by the industry over many years.

Failure to follow these minimum guidelines can jeopardize perfor-

mance of the roof system and warranty issuance.

All edge flashing details should be designed and installed to meet the *FMRC Loss Prevention Data Bulletin #1-49* requirements. However, some local code requirements may take precedence regarding certain design items. Designers and contractors should acquaint themselves with pertinent local code requirements, which may change from time to time.

"Alternate" details 1a, 2a & 4a in this publication may not meet specific wind uplift resistance requirements, according to the FMRC 1-49 requirements.

TABLE OF DETAIL DRAWINGS

- | | |
|--|--|
| 1. Draining Edge with Gutter | 14. Low Profile Raised Expansion Joint |
| 1a Draining Edge with Gutter, alternate | 14A Low Profile Prefab Expansion Joint |
| 2. Flat Draining Edge (Drip Edge, Gravel Stop) | 15. Thru Wall Scupper |
| 2a Flat Draining Edge (Drip Edge, Gravel Stop), alternate | 16. Scupper Thru Raised Roof Edge |
| 3. Raised Roof Edge (with Cant Edge) | 17. Roof Drain Without Lead Flashing |
| 4. Low Raised Edge (with Tapered Edge) | 18. Roof Drain With Lead Flashing |
| 4a Low Raised Edge (with Tapered Edge), alternate | 19. Sheet Metal Pan Roof Drain |
| 5. Low Parapet Wall | 20. Skylight, Hatch and Smoke Vent Curbs |
| 6. Parapet Wall End Termination | 21. Roof Top Air Handling Units |
| 7. High Parapet with Multi-Ply Base Flashing | 22. Insulated Steel Deck Frame Support |
| 7A High Parapet Base Flashing at Plywood Walls | 23. Concrete Deck Frame Support |
| 7B High Parapet Base Flashing at Masonry Walls | 24. Pipe Support with Roller Assembly |
| 7c Multi-Ply Base Flashing at Masonry Parapets | 25. Equipment or Sign Support Rail |
| 7D Multi-Ply Base Flashing, Stone Capped Masonry Walls | 26. Pipe and Flashing Clearances |
| 7E Multi-Ply Base Flashing at EIFS Walls | 27. Mechanical Equipment Stand |
| 8. Base Flashing for Wall Supported Deck | 28. Plumbing Vent Flashing |
| 9. Base Flashing for Non-Wall Supported Deck | 29. Approved One-Way Vents |
| 10. Base Flashing for Vented Base Sheet | 30. Hot Stack Flashing Curb |
| 11. Typical Termination Bar Counterflashing | 31. Piping Thru Roof Deck |
| 12. Area Divider Curb | 32. Typical Pitch Pan |
| 13. Curb Type Expansion Joint | 33. Split Repair |

NOTE: Lower case "a" designates an *alternate* detail, and upper case letters with detail numbers indicate *additional* similar details.

For other details, not shown, Contact BITEC's Technical Services Department at (800) 535-8597

1. Draining Edge with Gutter

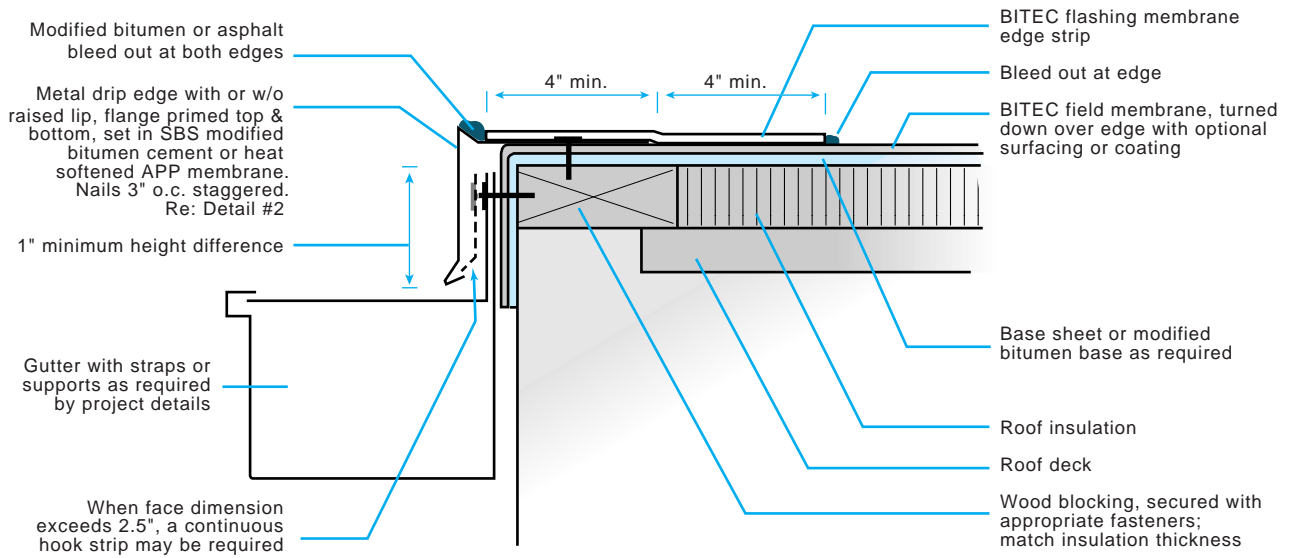

1a. Draining Edge with Gutter, alternate

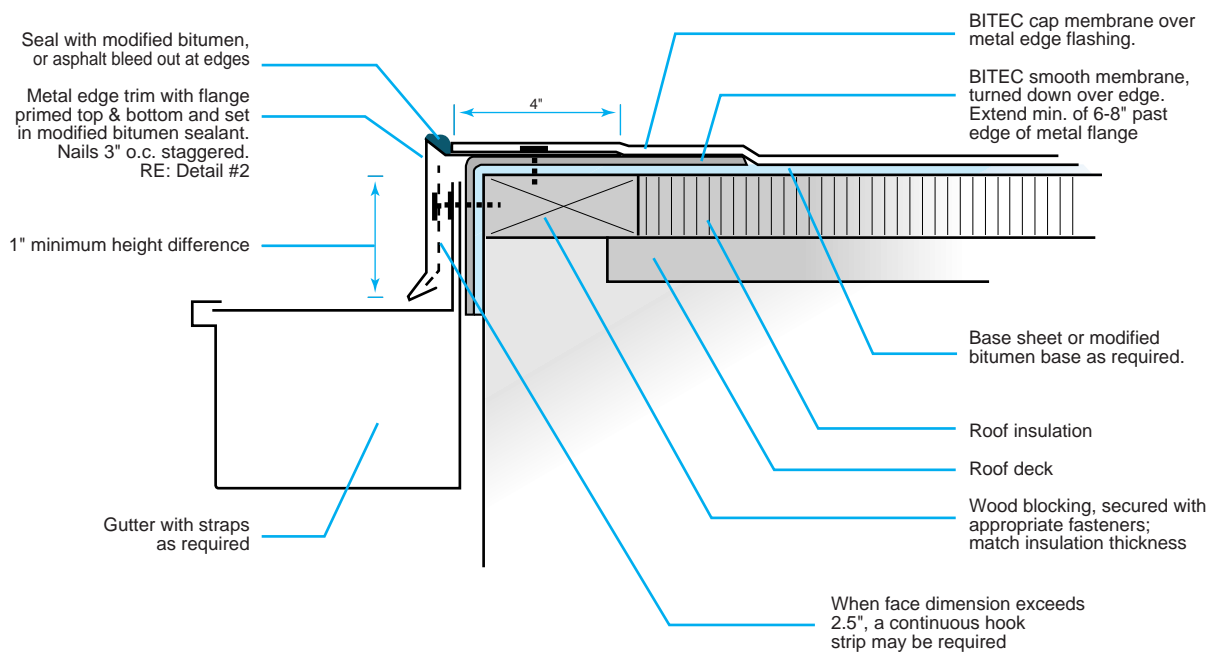

CAUTION: This alternate edge detail is not in compliance with FM Loss Prevention Data Bulletin I-49 for Perimeter Flashings

2. Flat Draining Edge (Drip Edge, Gravel Stop)

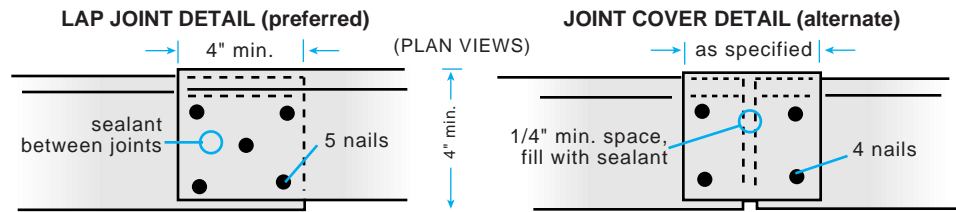
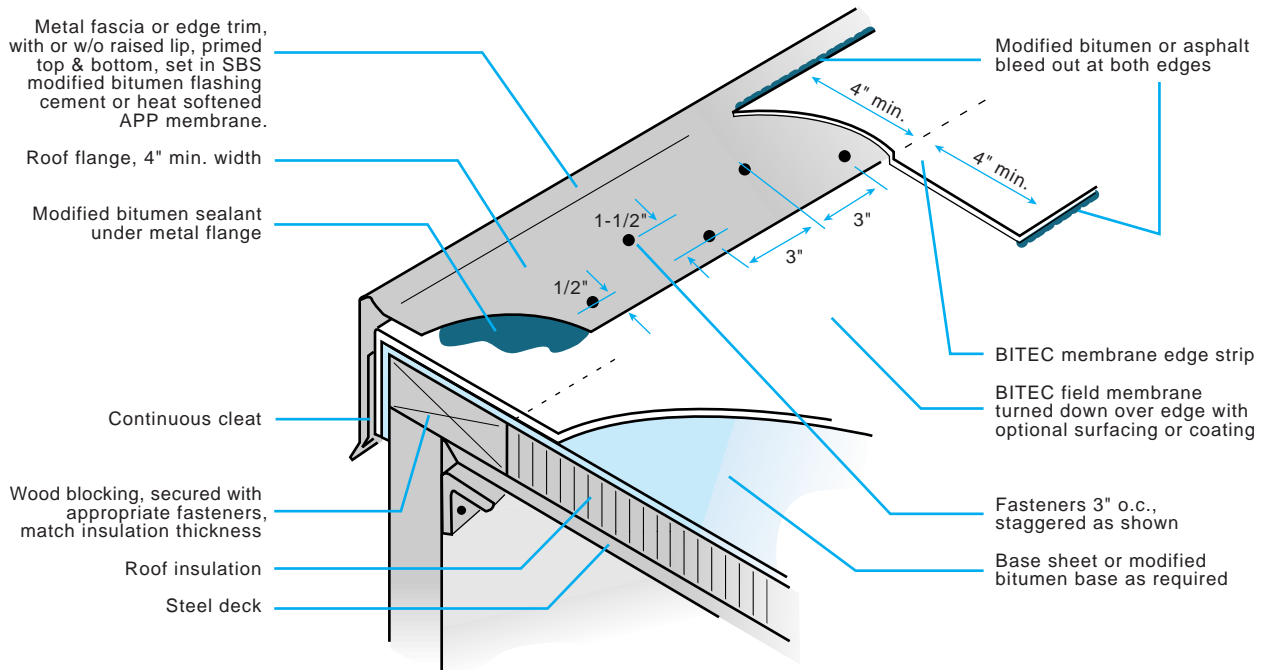

2a. Flat Draining Edge (Drip Edge, Gravel Stop), alternate

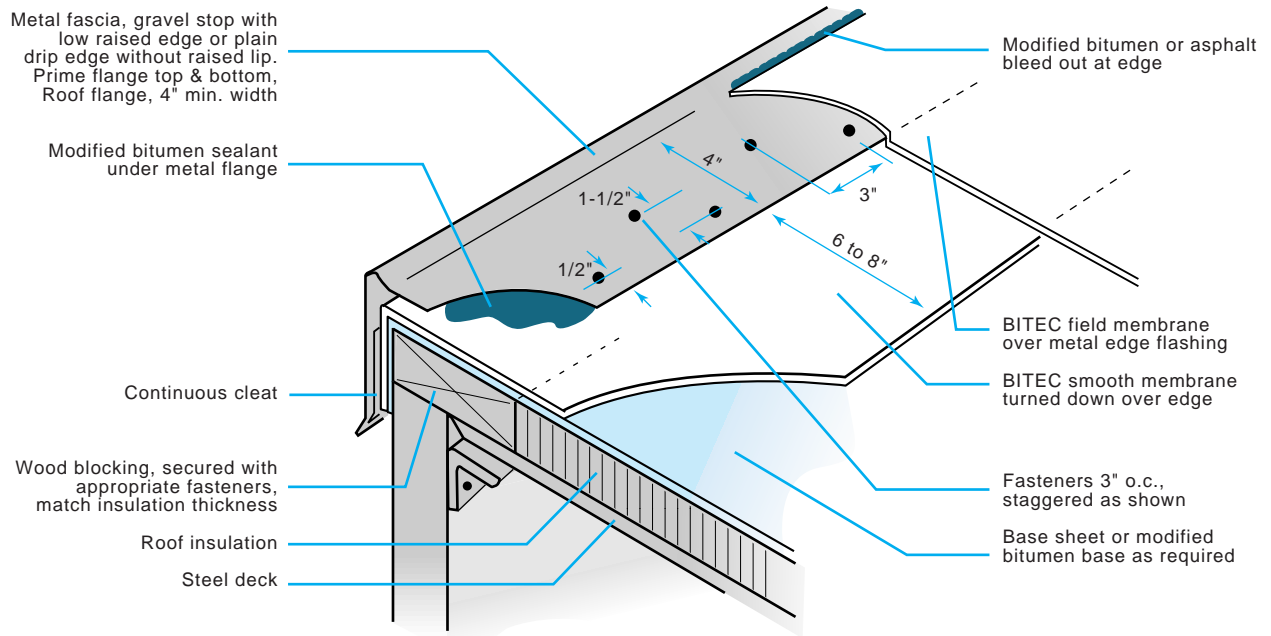

(See Lap Joint detail - #2)

CAUTION: This alternate edge detail is not in compliance with FM Loss Prevention Data Bulletin I-49 for Perimeter Flashings

3. Raised Roof Edge (with Cant Edge)

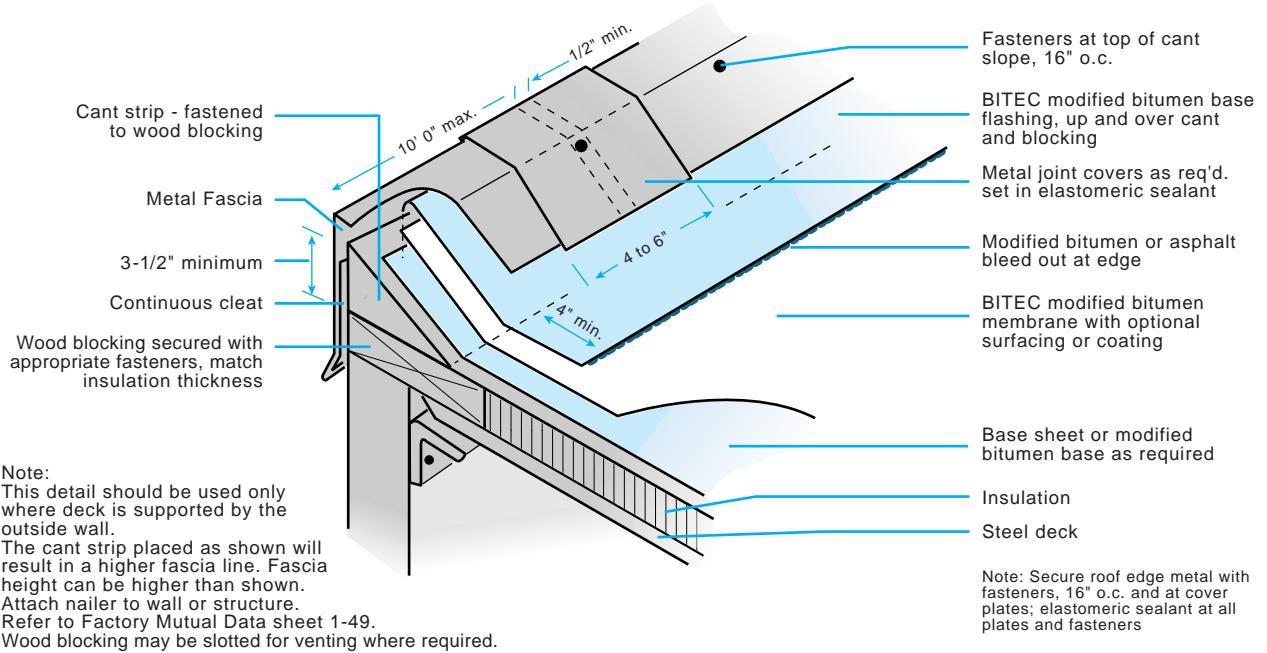

4. Low Raised Edge (with Tapered Edge)

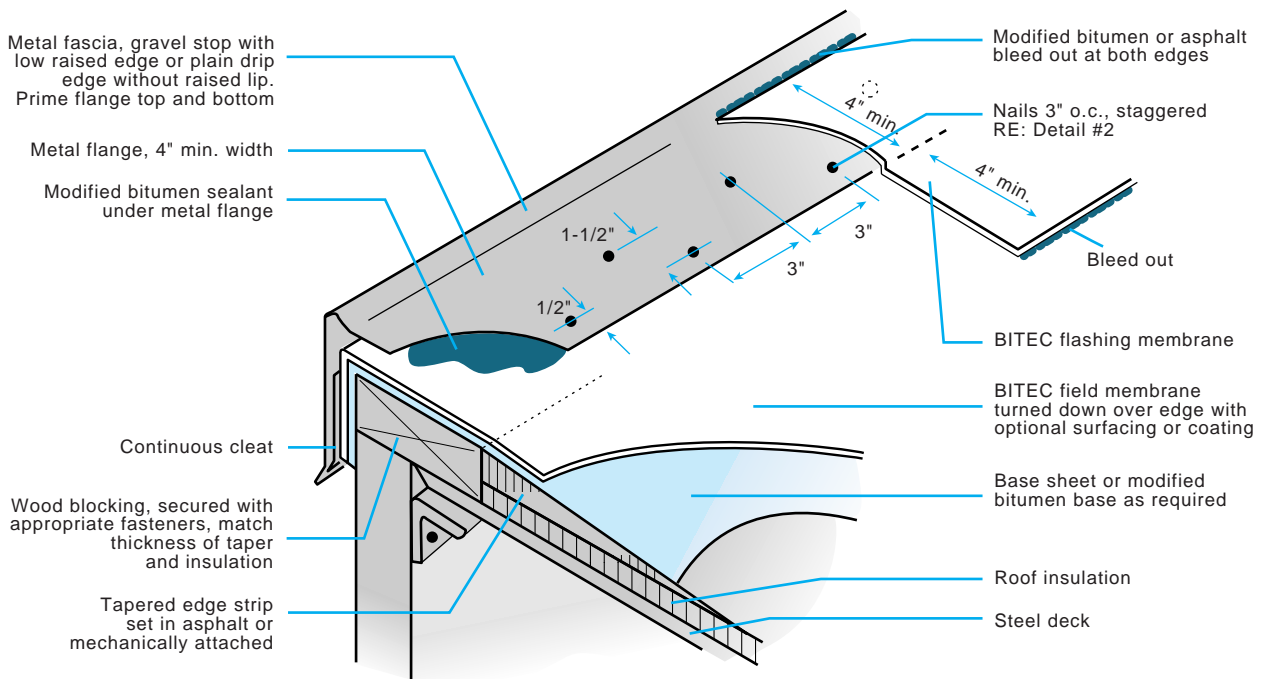

LAP JOINT DETAIL (preferred)

JOINT COVER DETAIL (alternate)

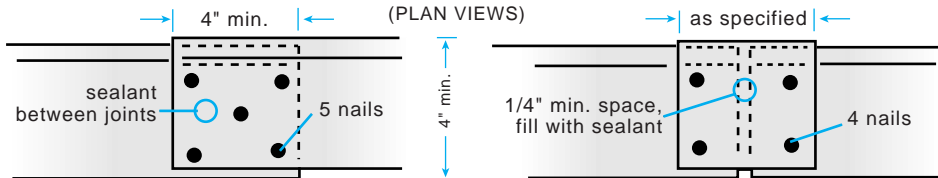

4a. Low Raised Edge (with Tapered Edge), alternate

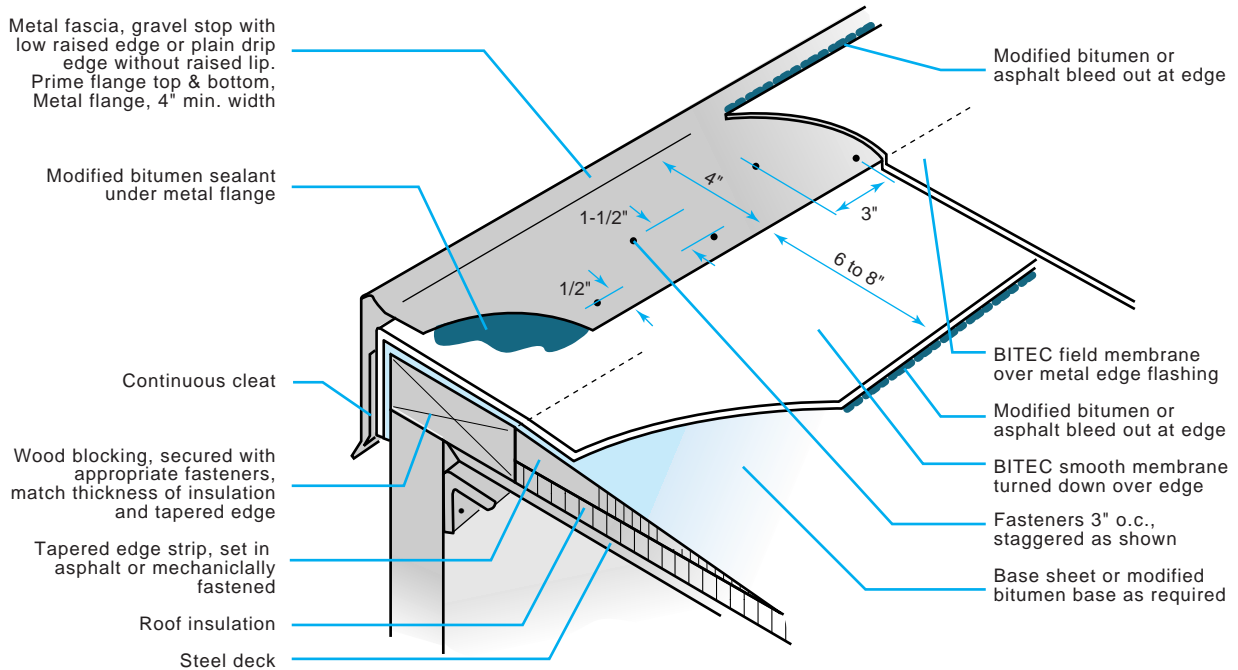

(See Lap Joint detail - #2)

CAUTION: This alternate edge detail is not in compliance with FM Loss Prevention Data Bulletin I-49 for Perimeter Flashings

5. Typical Parapet Wall (for 2-Ply Systems)

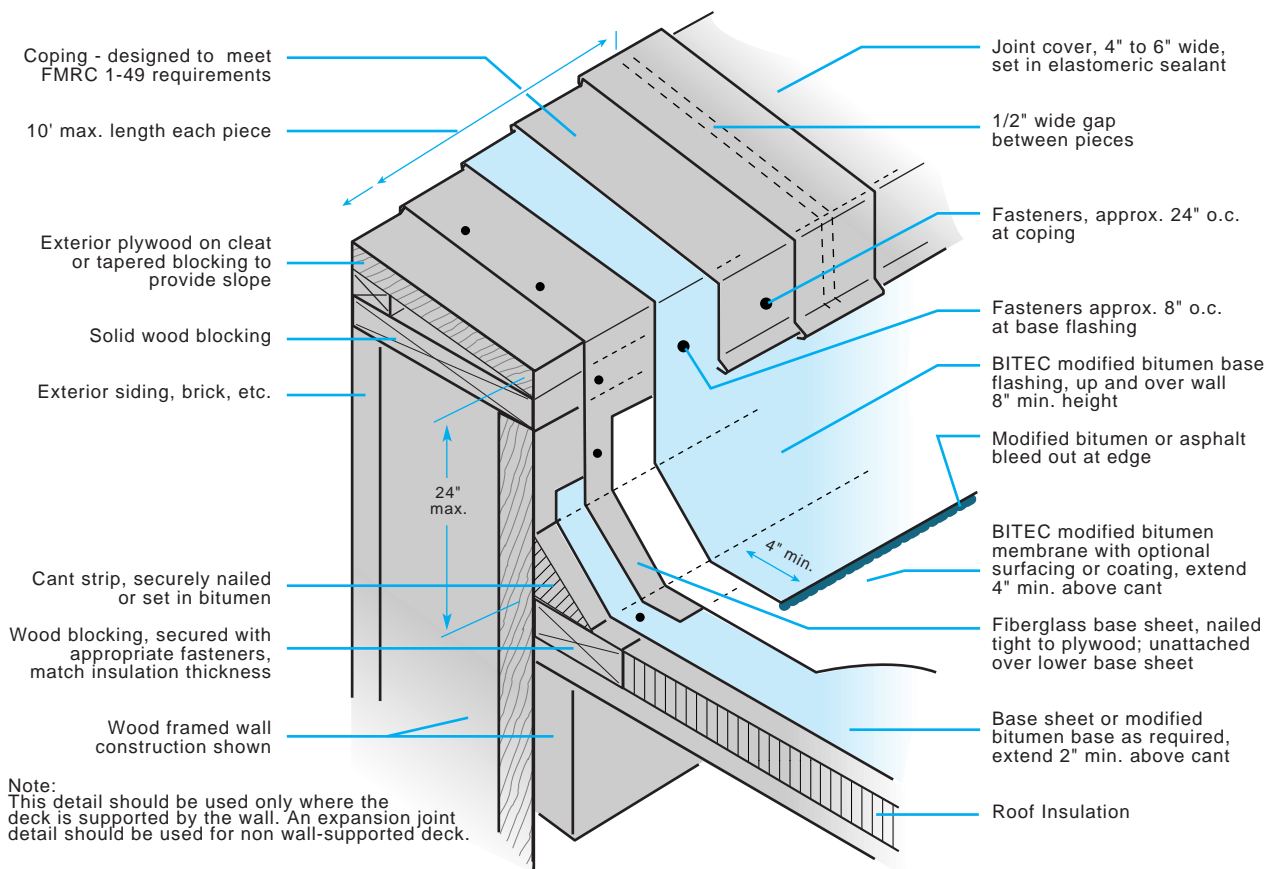

Note:
This detail should be used only where the deck is supported by the wall. An expansion joint detail should be used for non wall-supported deck.

6. Parapet Wall End Termination

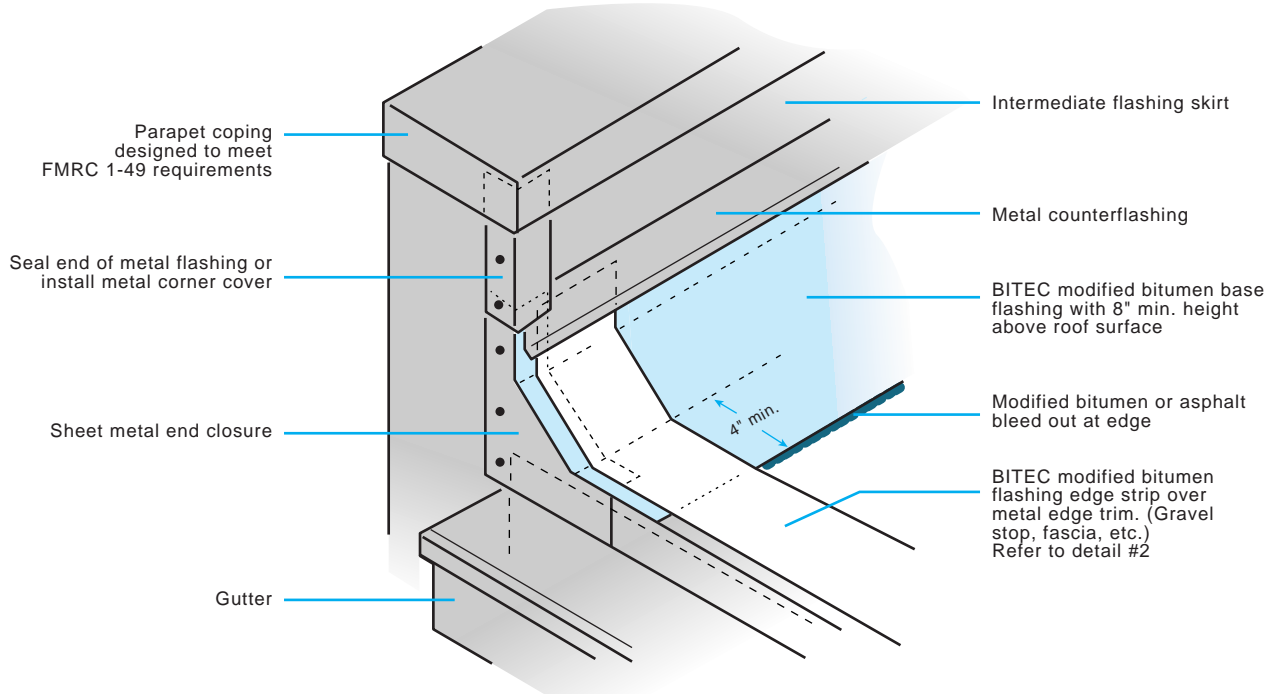

7. Multi-Ply Base Flashing at Plywood Parapets

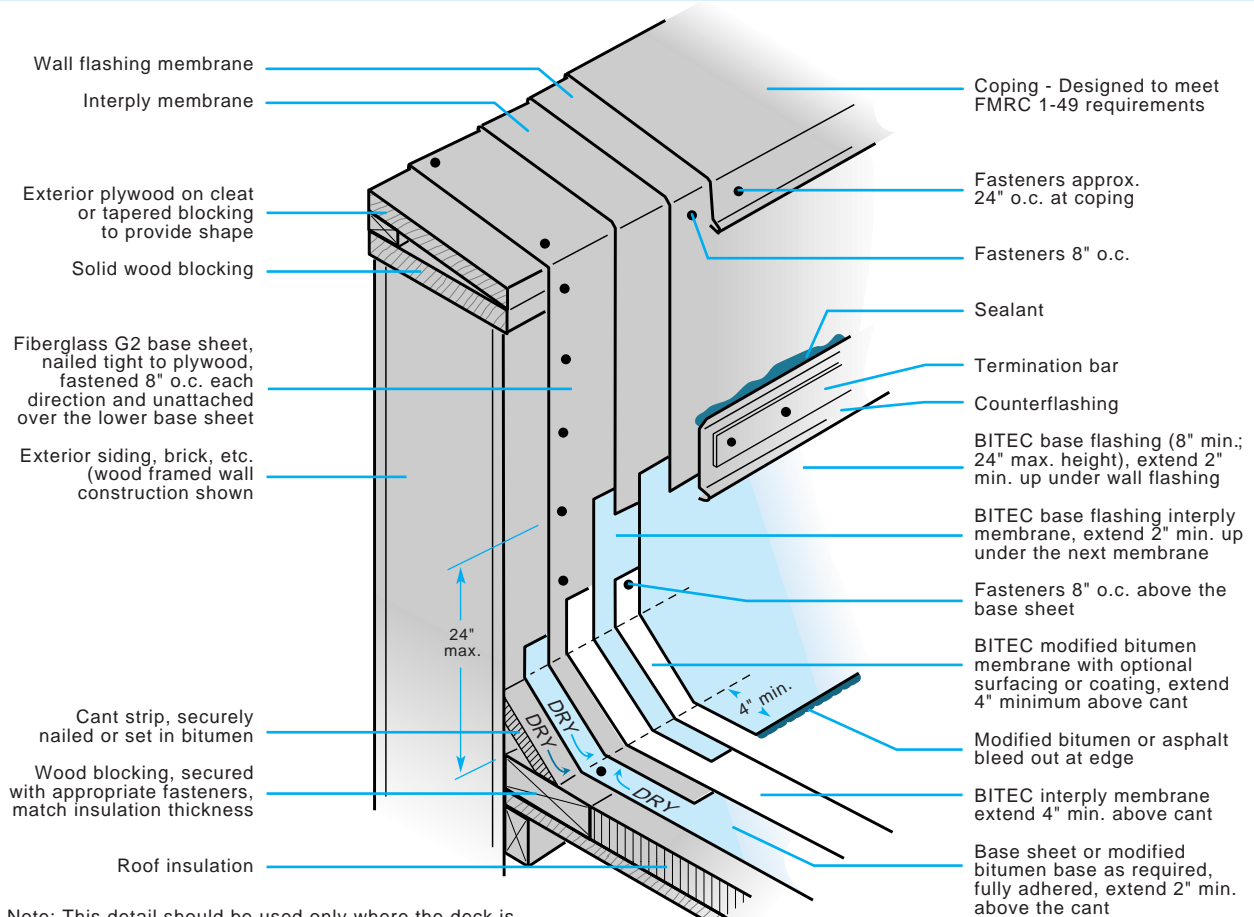

Note: This detail should be used only where the deck is supported by the wall. An expansion joint detail should be used for non wall-supported deck. Contact BITEC Technical Services for suitability of attachment at cants if building movement is not a concern.

7A. High Parapet Base Flashing at Plywood Walls

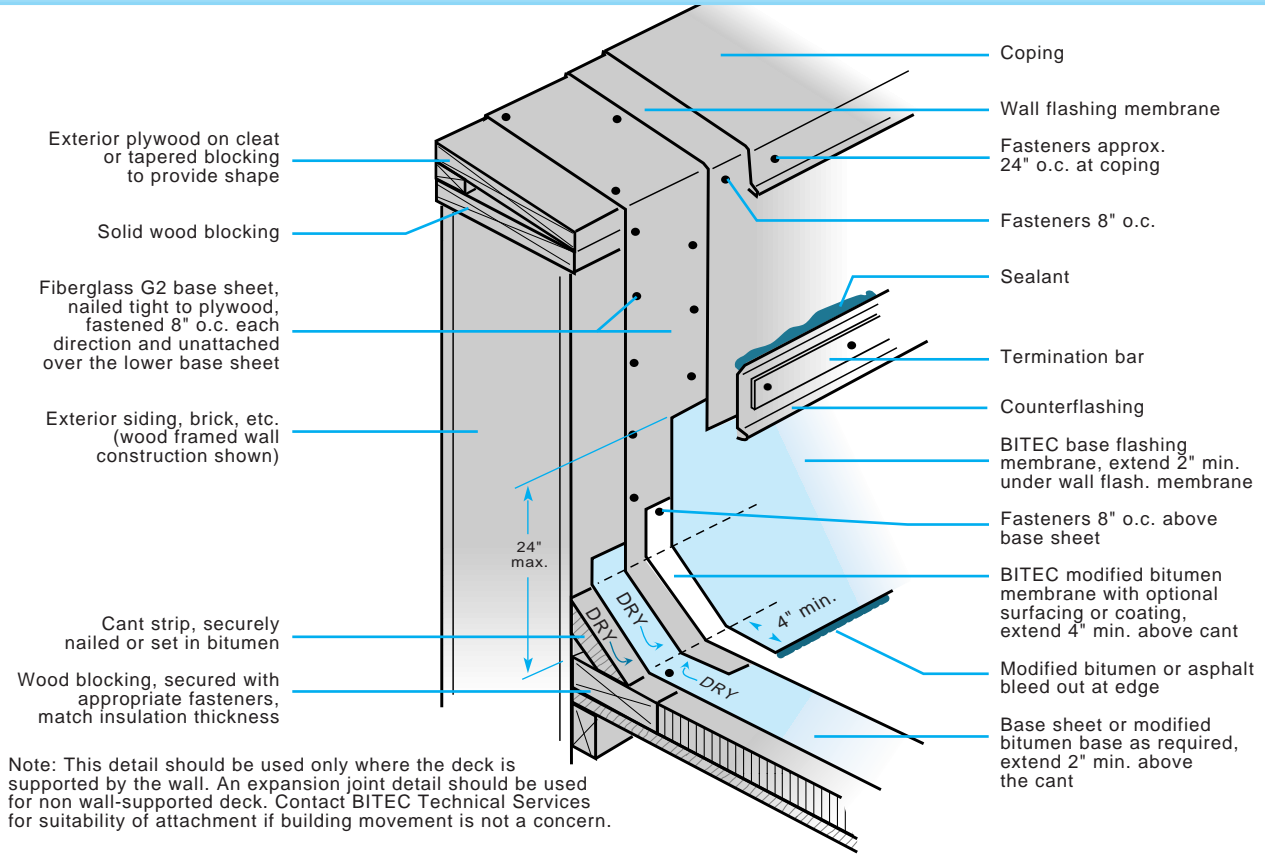

7B. High Parapet Base Flashing at Masonry Walls

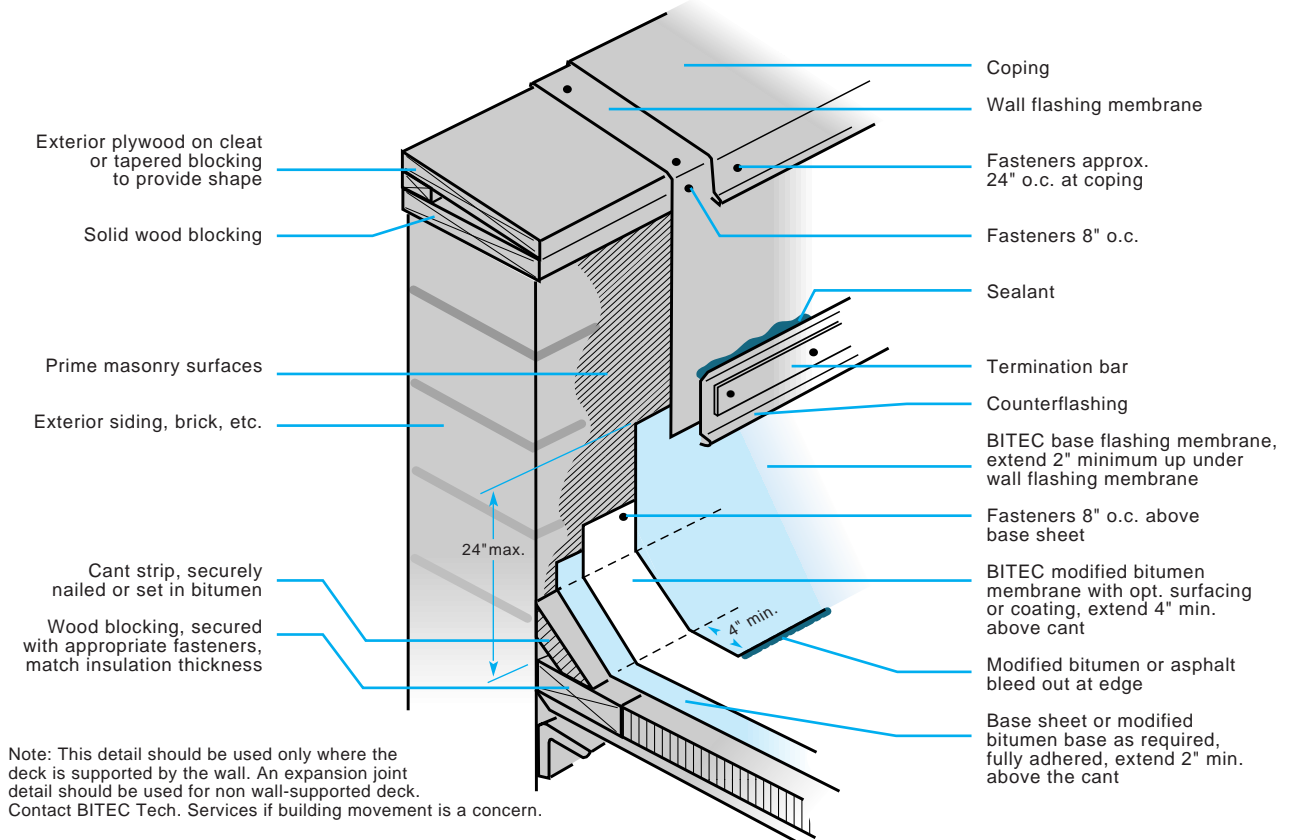

7C. Multi-ply Base Flashing at Masonry Parapets

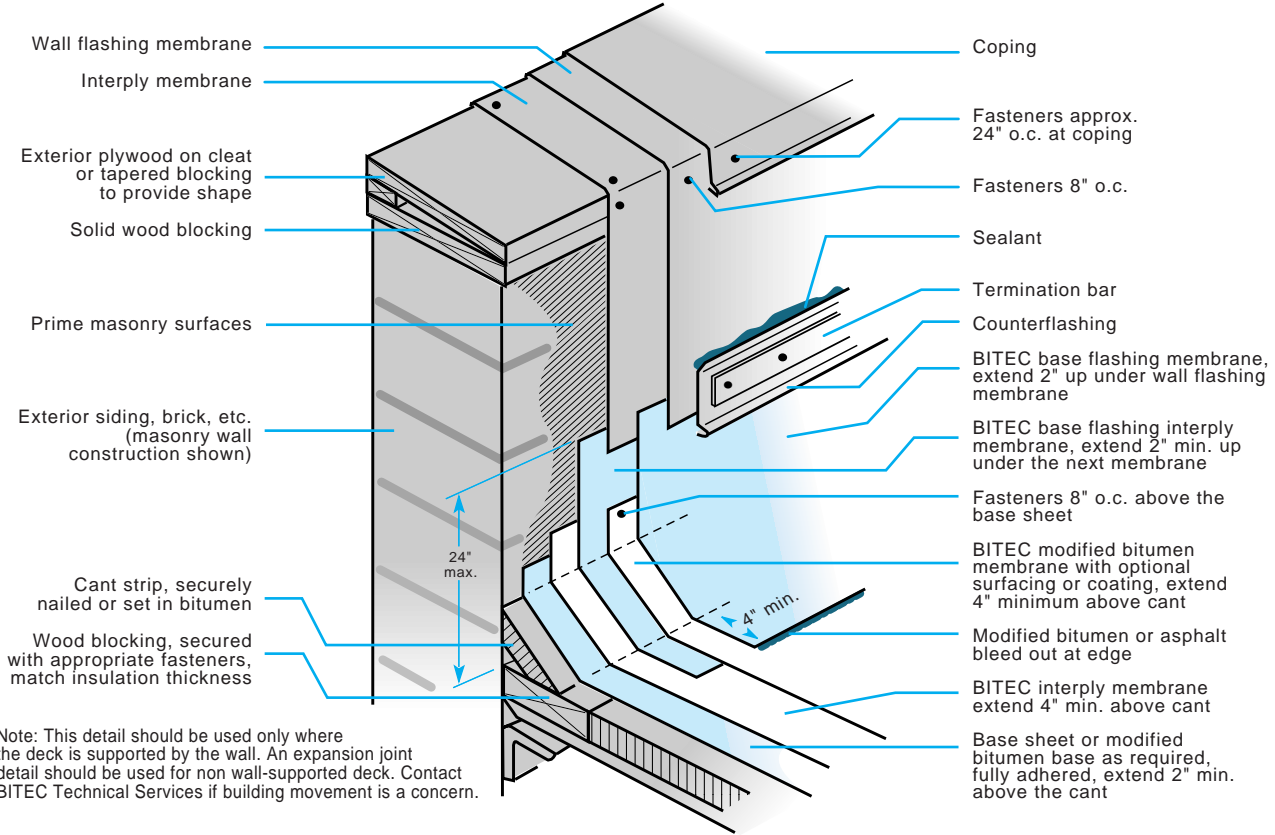

7D. Multi-ply Base Flashing, Stone capped masonry walls

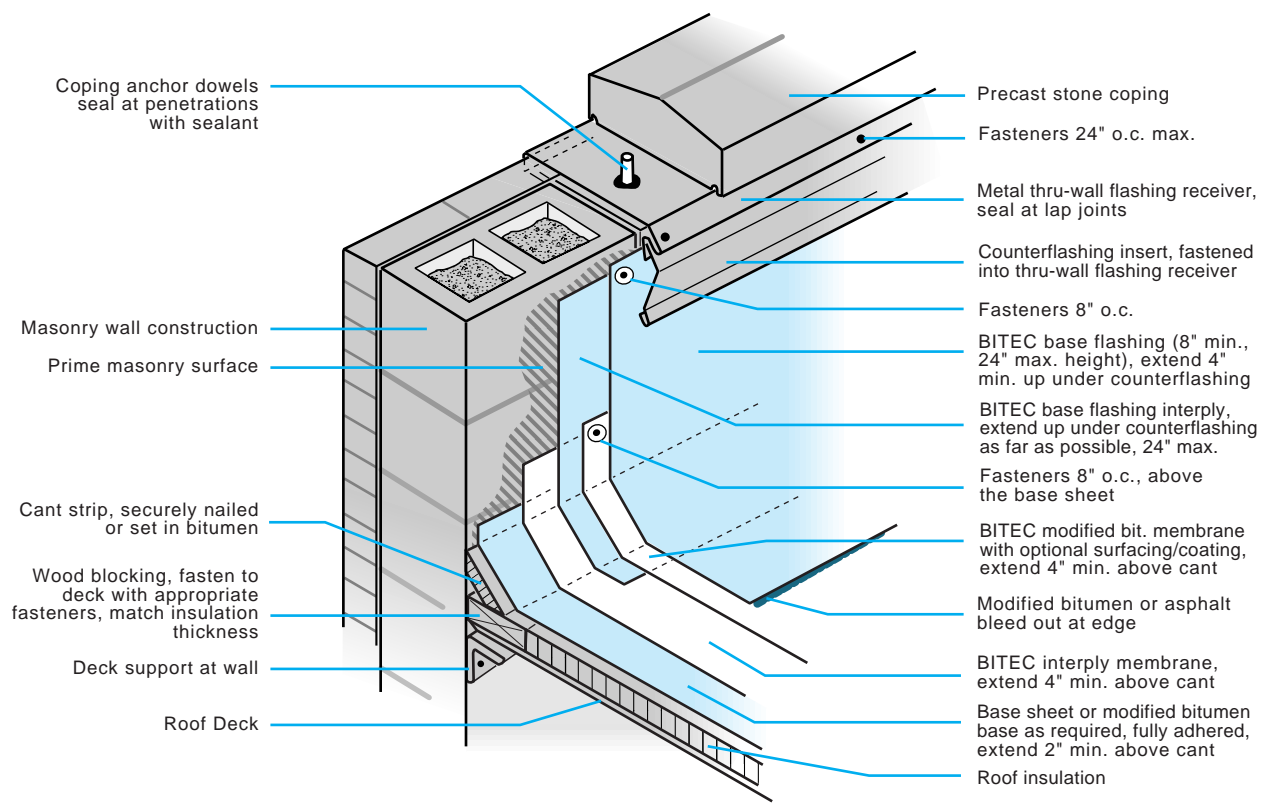

7E. Multi-ply Base Flashing at EIFS walls

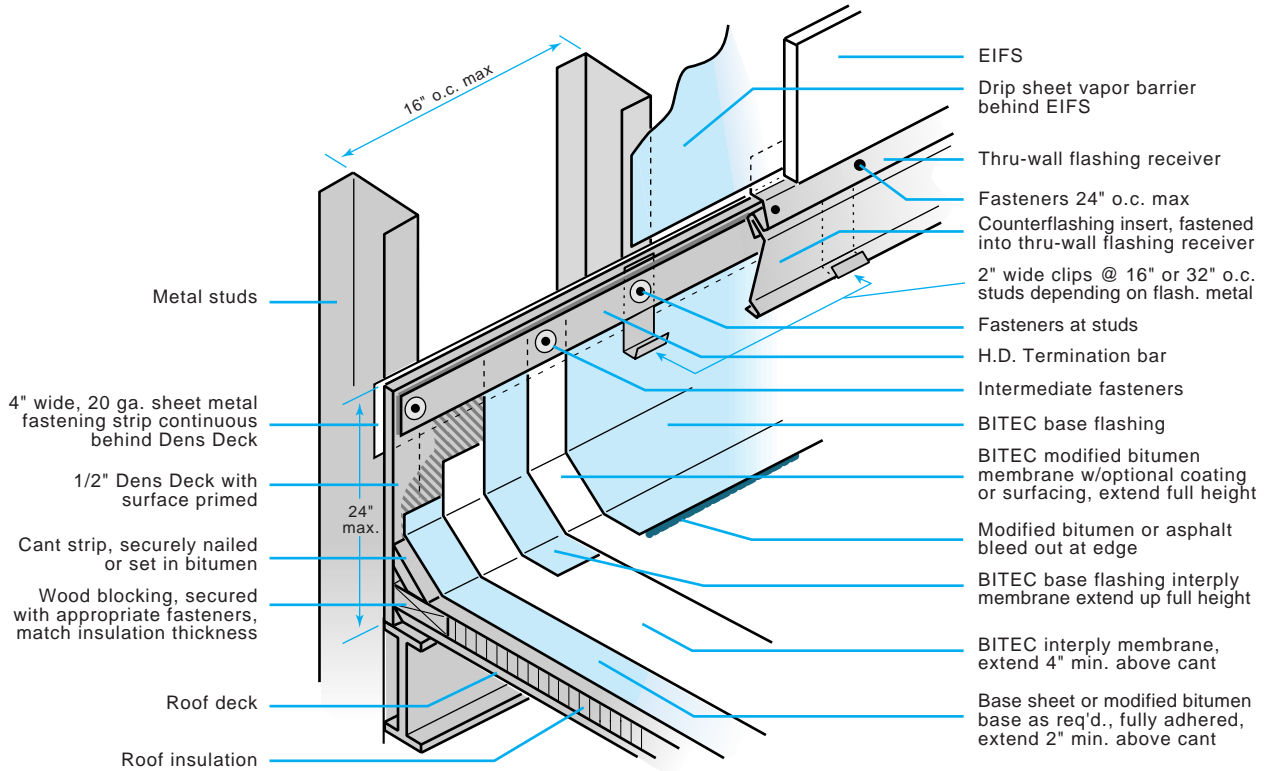

8. Base Flashing for Wall Supported Deck

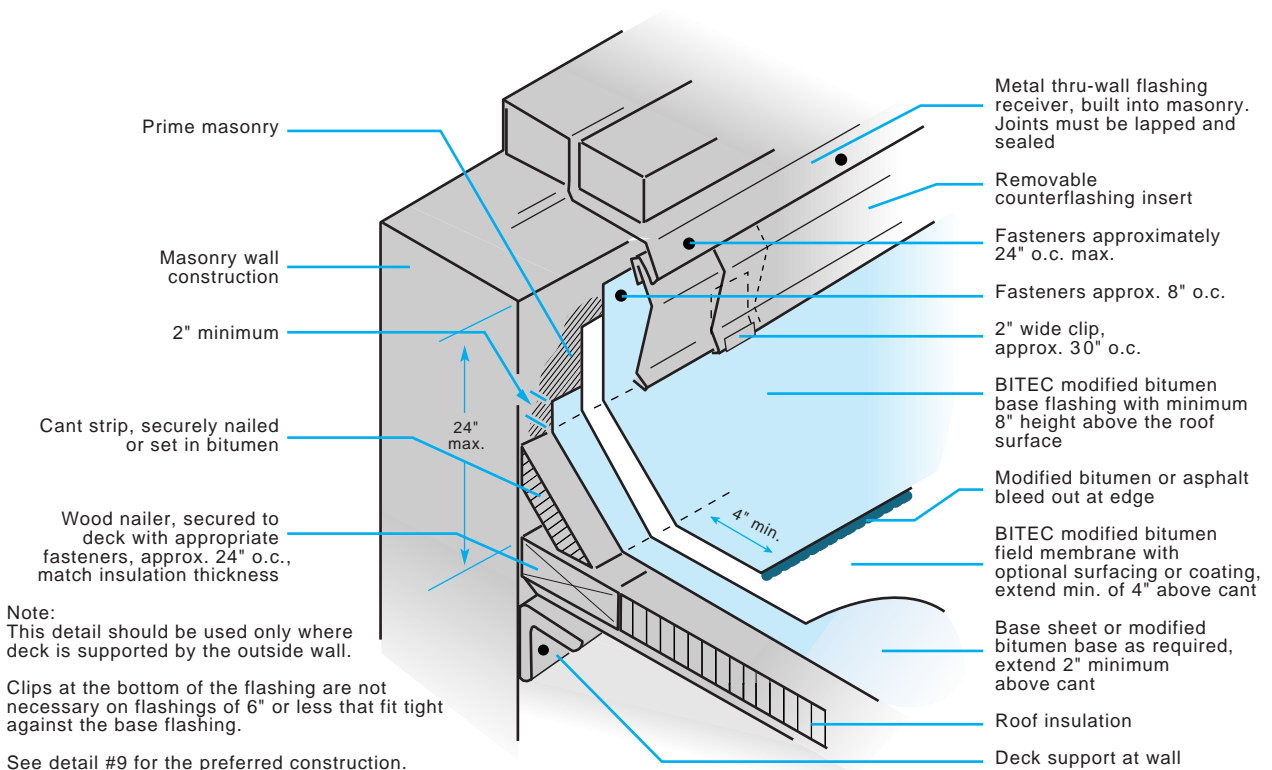

9. Base Flashing for Non Wall Supported Deck

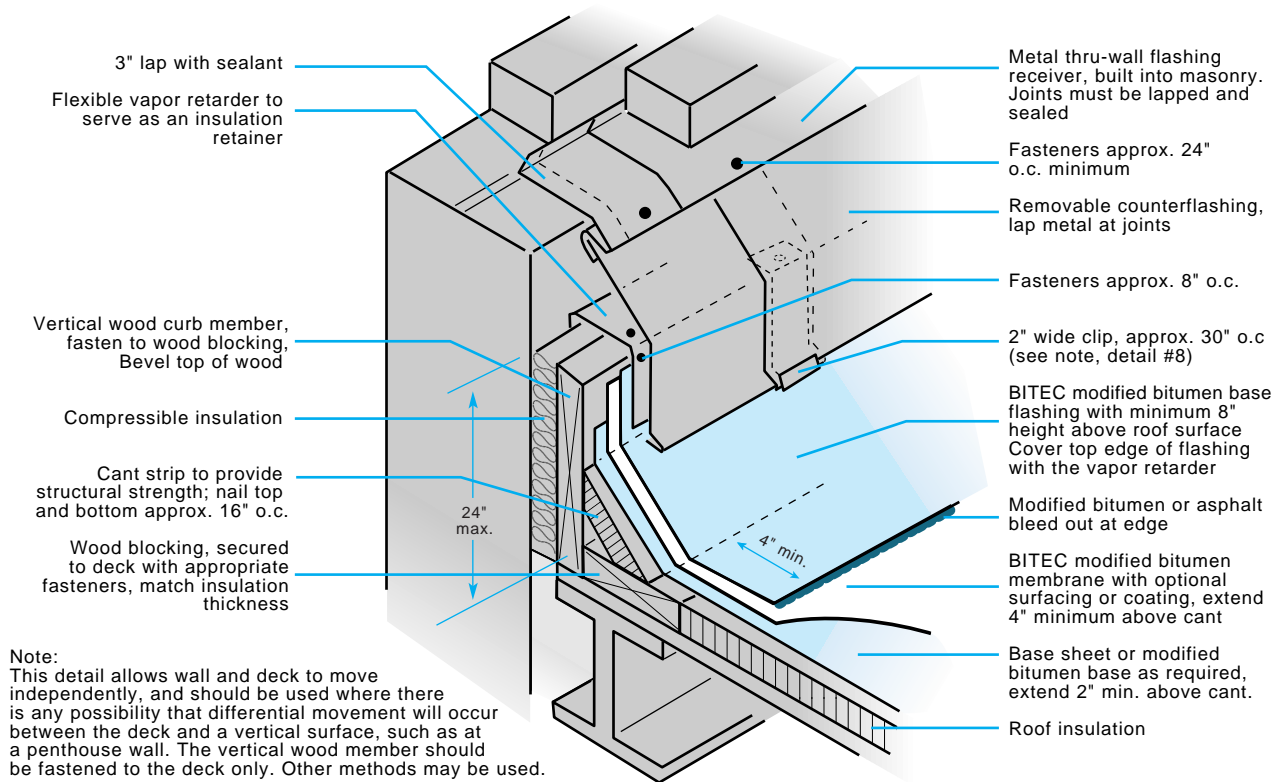

10. Base Flashing for Vented Base Sheet

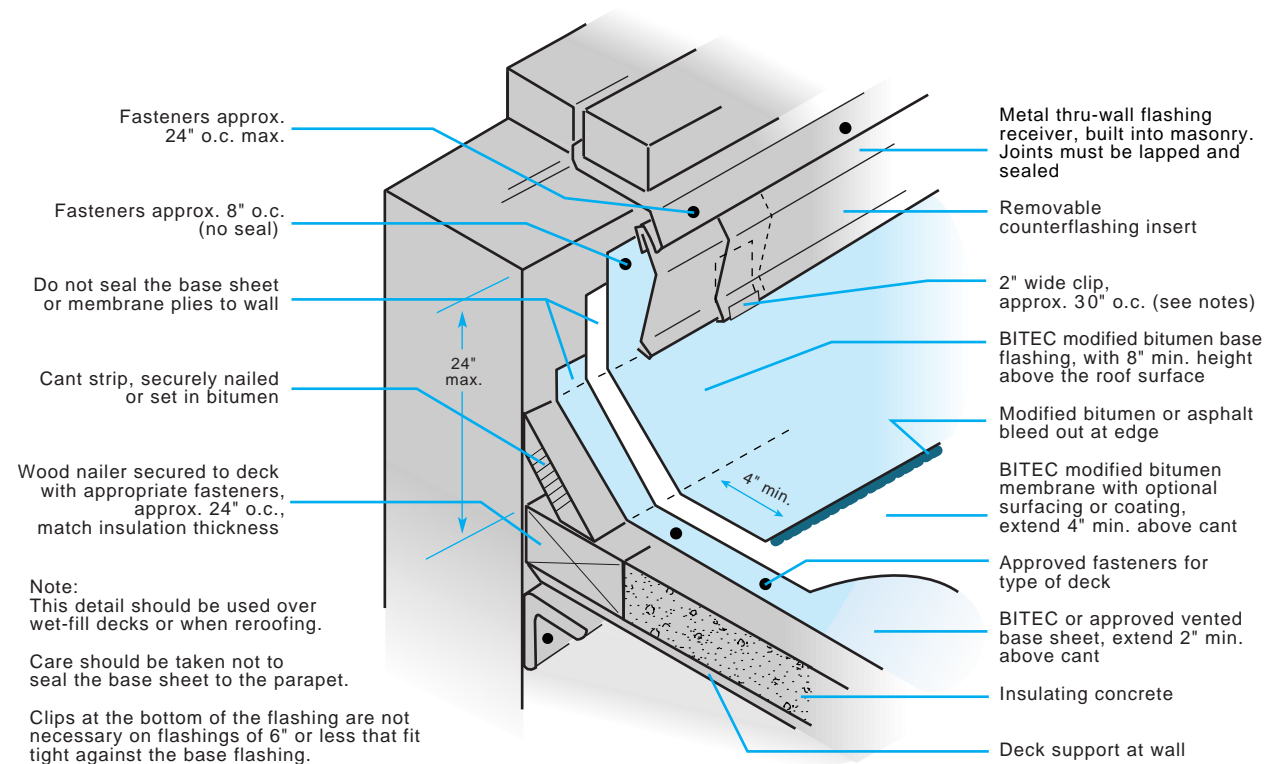

11. Typical Termination Bar Counterflashing

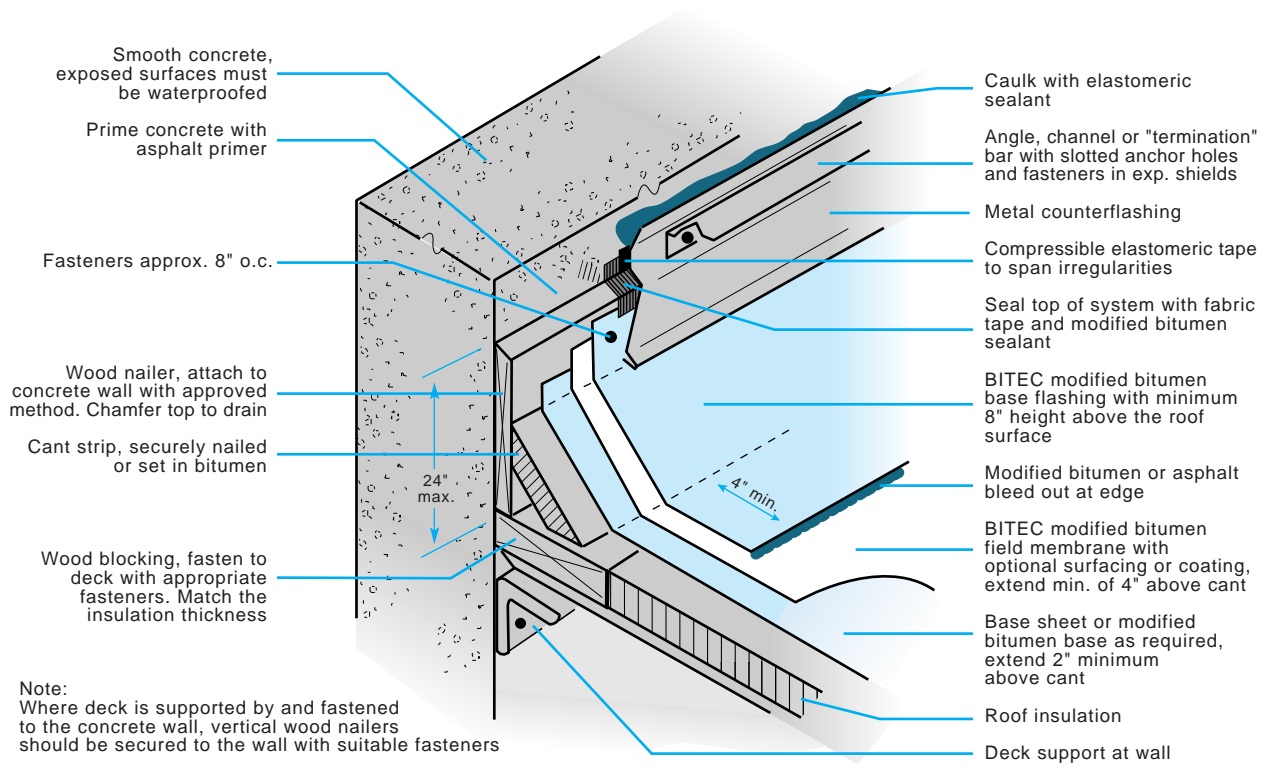

12. Area Divider Curb

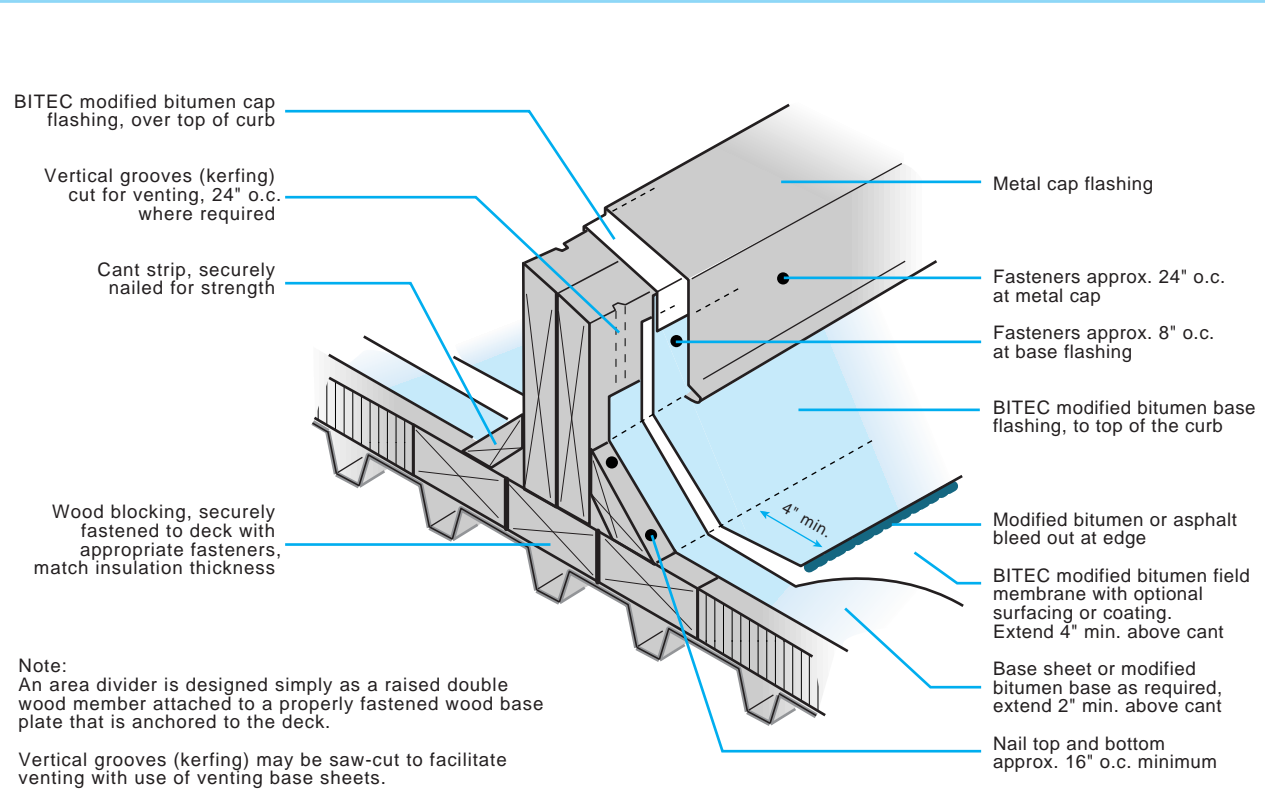

13. Curb Type Expansion Joint

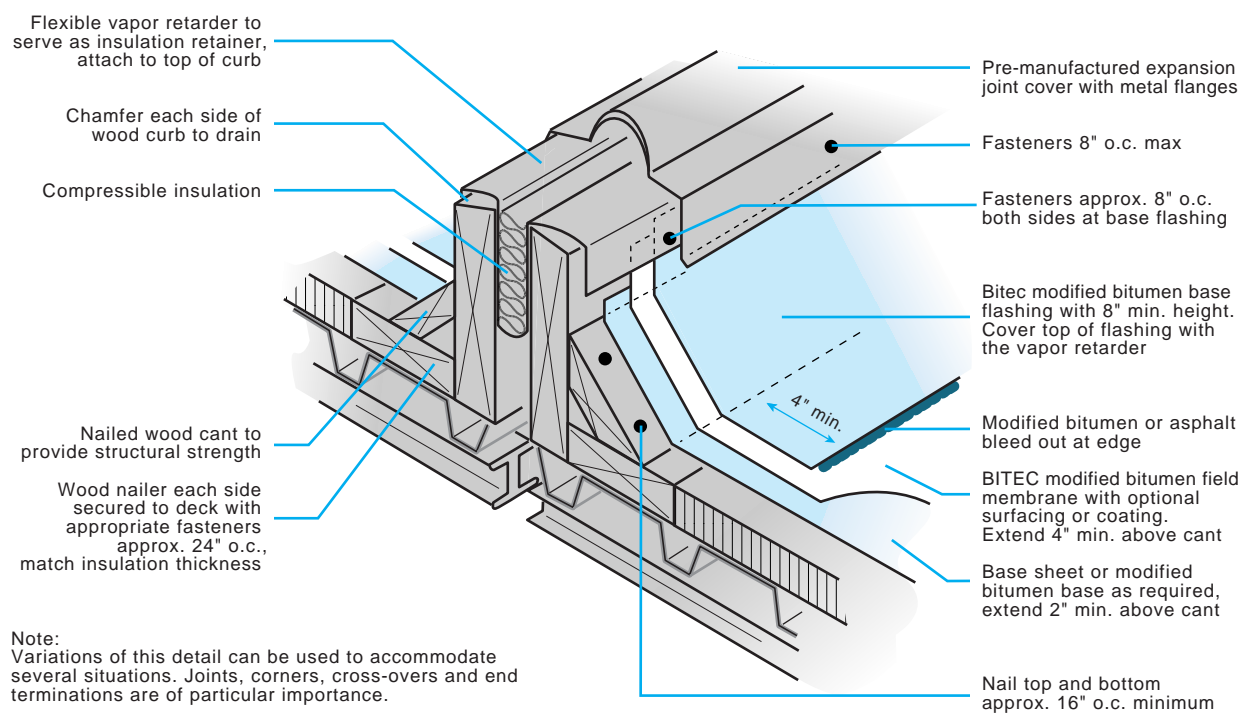

14. Low Profile Raised Expansion Joint

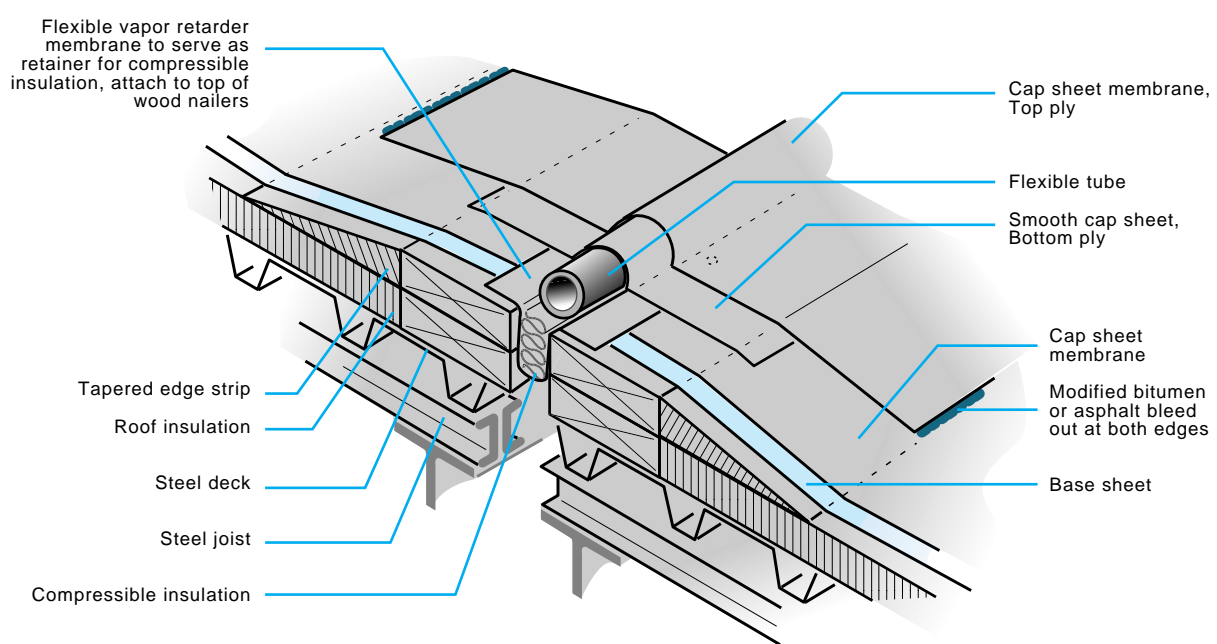

14A. Low Profile Prefab Raised Expansion Joint

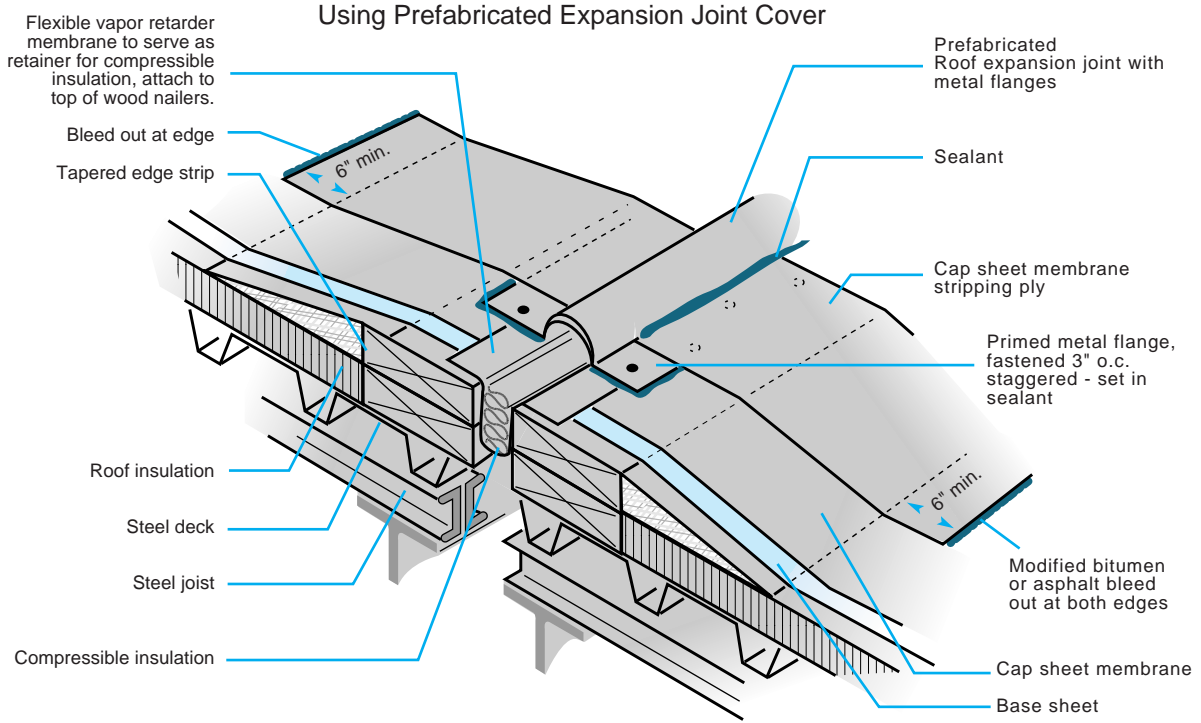

15. Thru-Wall Scupper

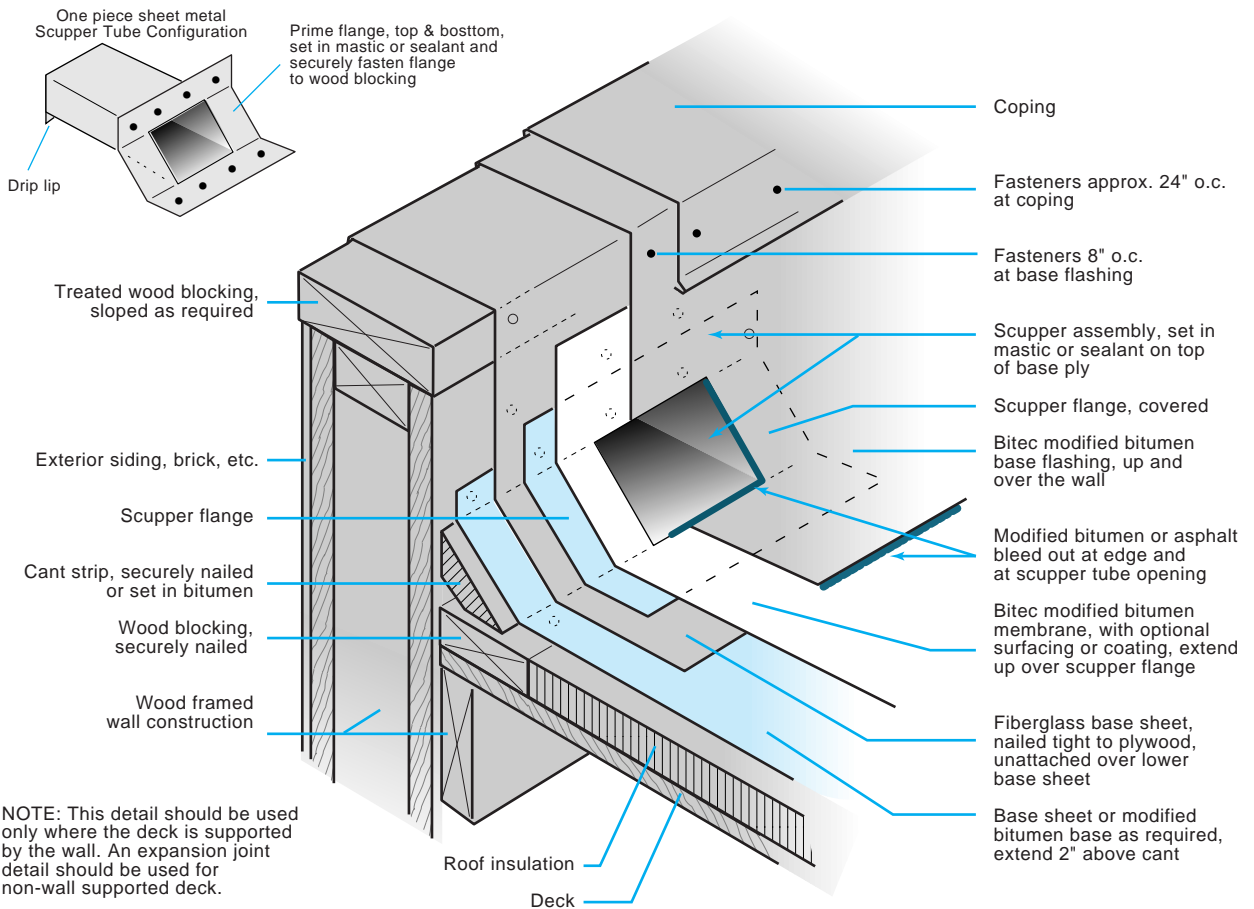

16. Scupper Through Raised Roof Edge

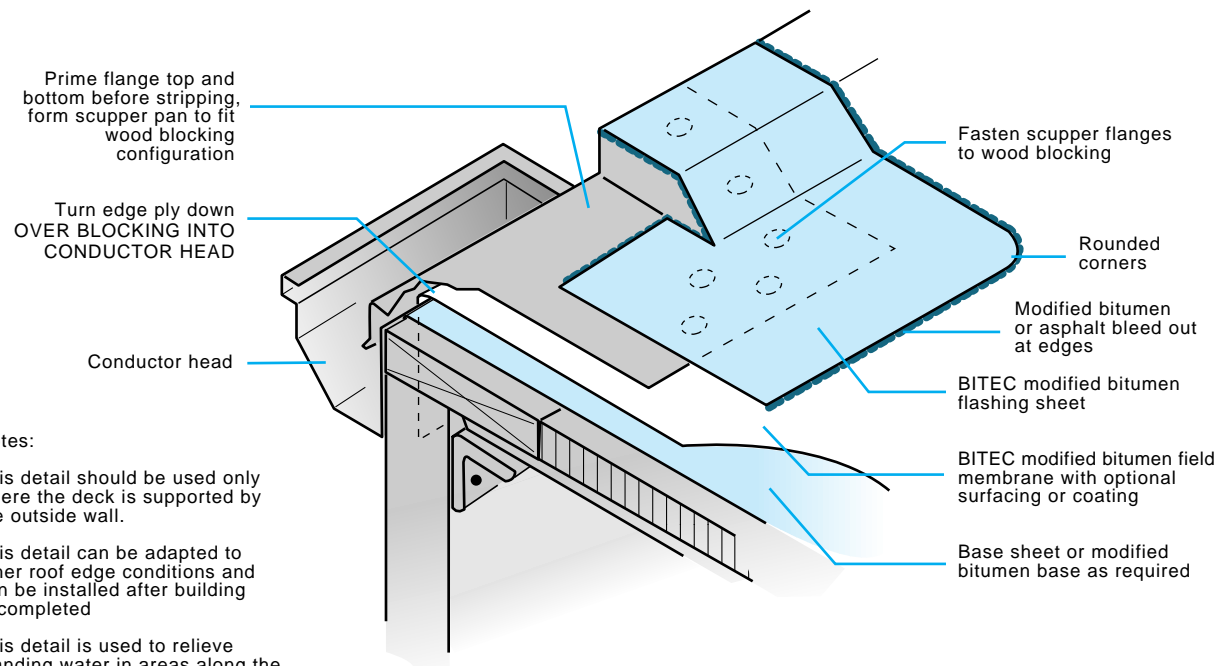

Notes:

This detail should be used only where the deck is supported by the outside wall.

This detail can be adapted to other roof edge conditions and can be installed after building is completed

This detail is used to relieve standing water in areas along the roof edge. All roof surfaces should be sloped to drain.

Attach nailer to wall. Refer to Factory Mutual data sheet 1-49. Wood blocking may be slotted for venting where required.

Cut-away view thru-scupper

17. Roof Drain without Lead Flashing

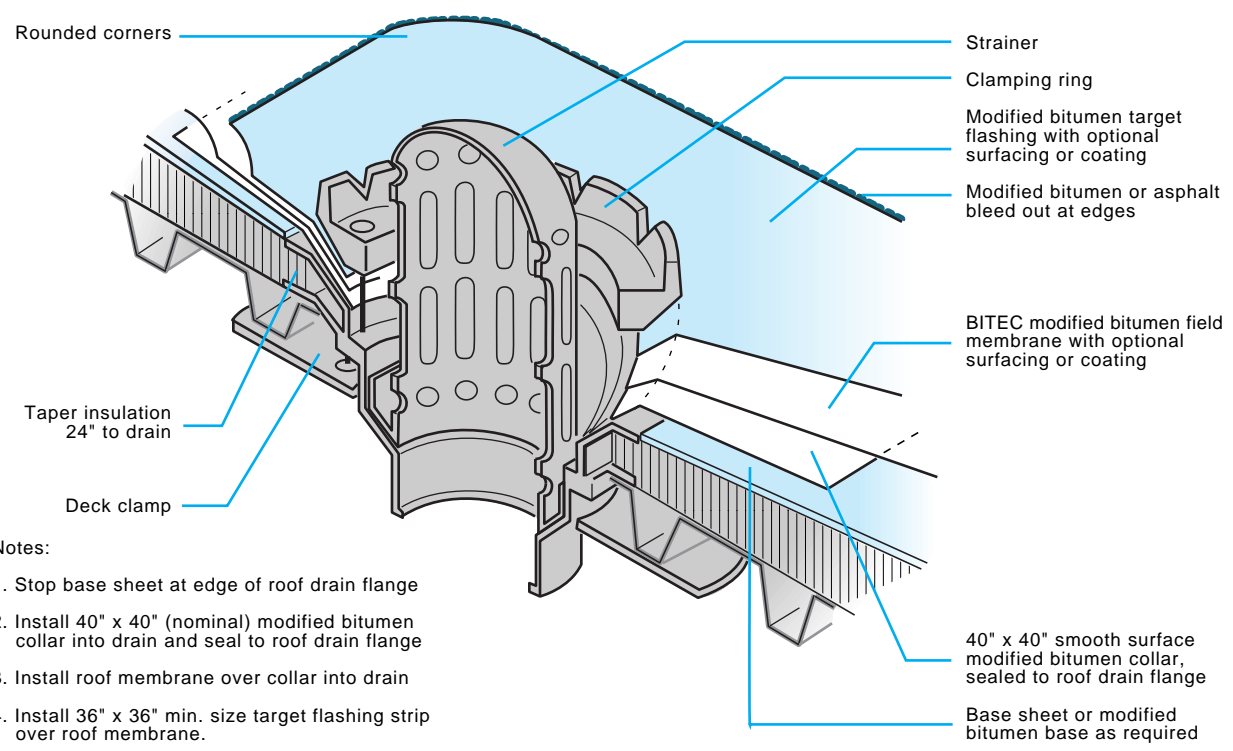

Notes:

1. Stop base sheet at edge of roof drain flange
2. Install 40" x 40" (nominal) modified bitumen collar into drain and seal to roof drain flange
3. Install roof membrane over collar into drain
4. Install 36" x 36" min. size target flashing strip over roof membrane.

18. Roof Drain with Lead Flashing

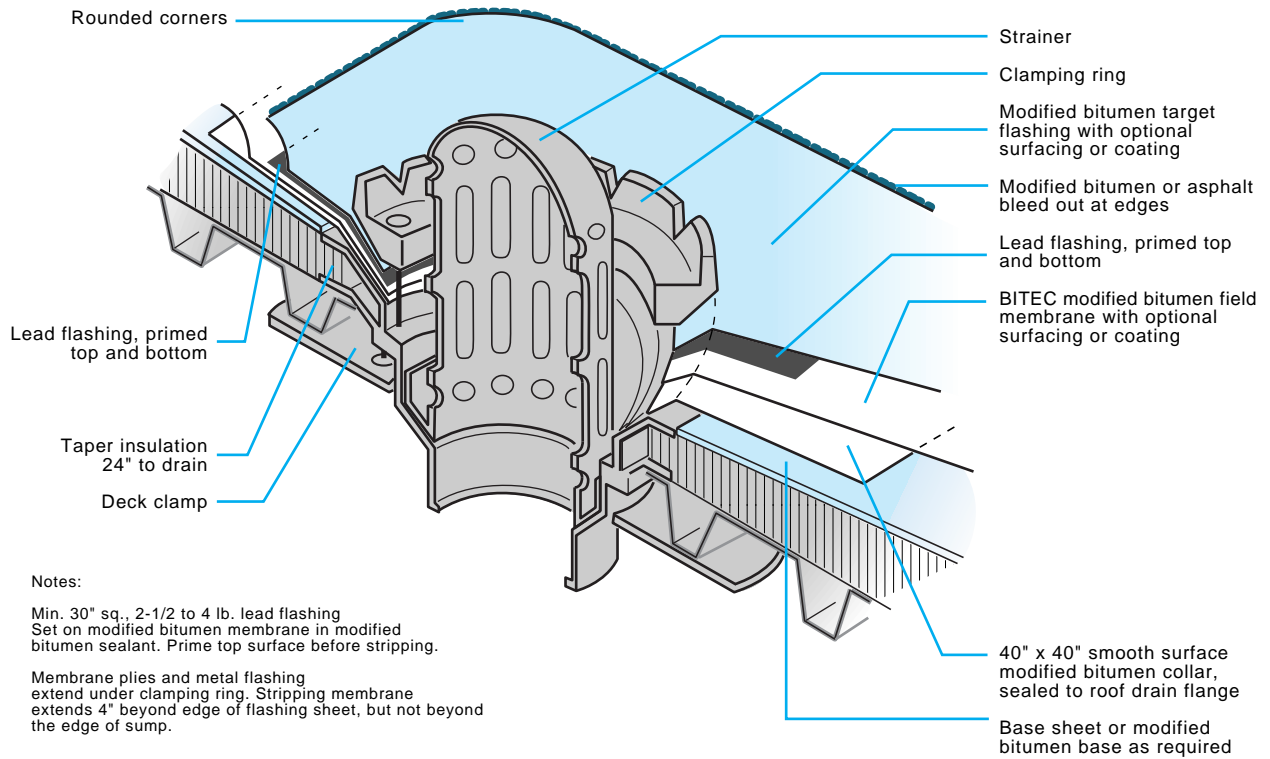

19. Sheet Metal Pan Roof Drain

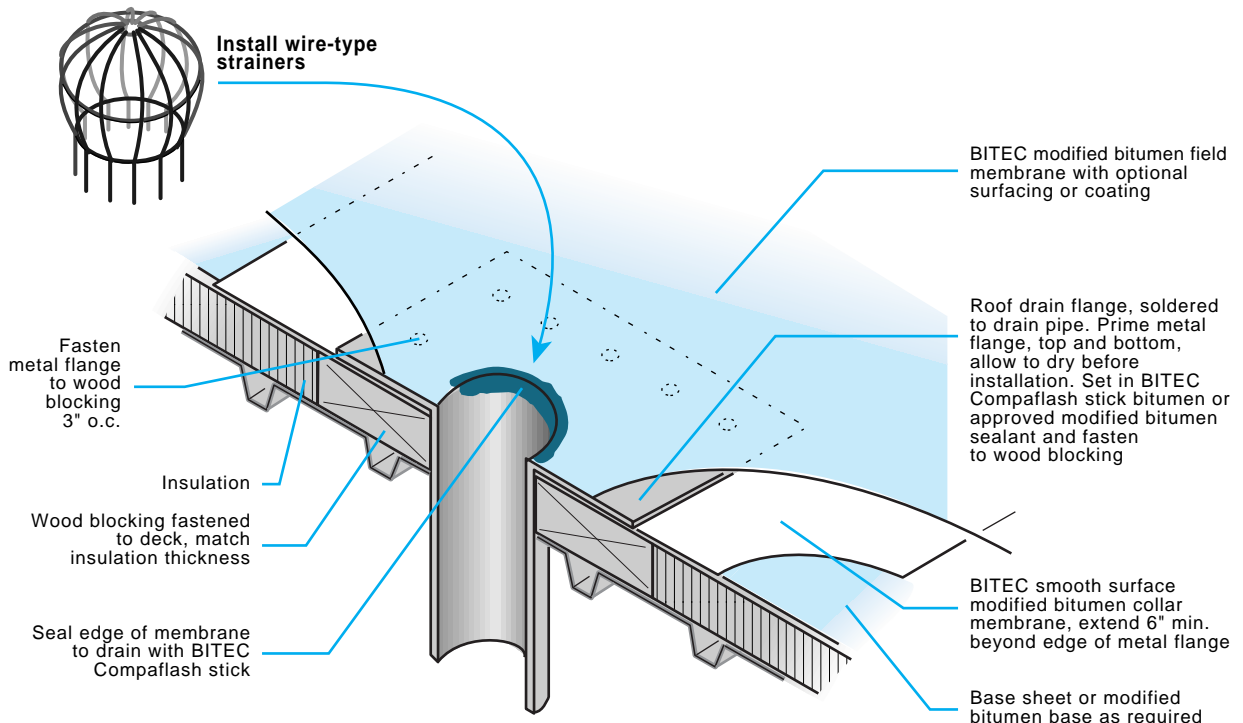

20. Skylight, Hatch and Smoke Vent Curbs

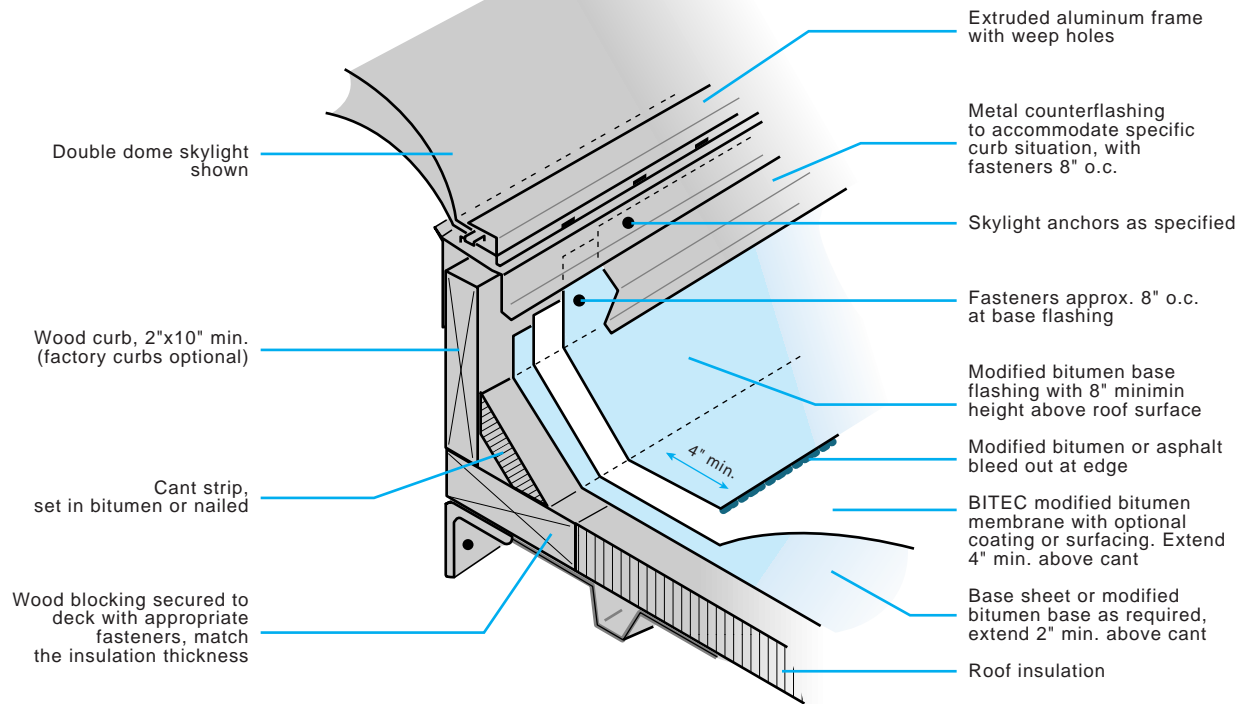

21. Roof Top Air Handling Units

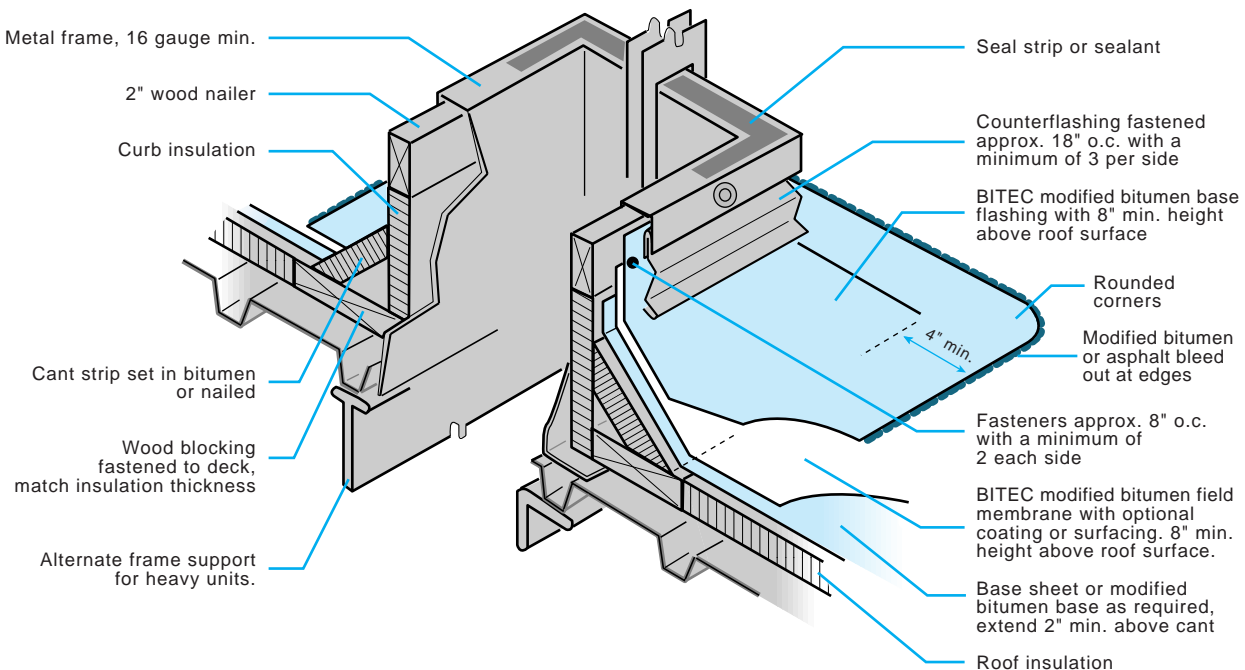

22. Insulated Steel Deck Frame Support

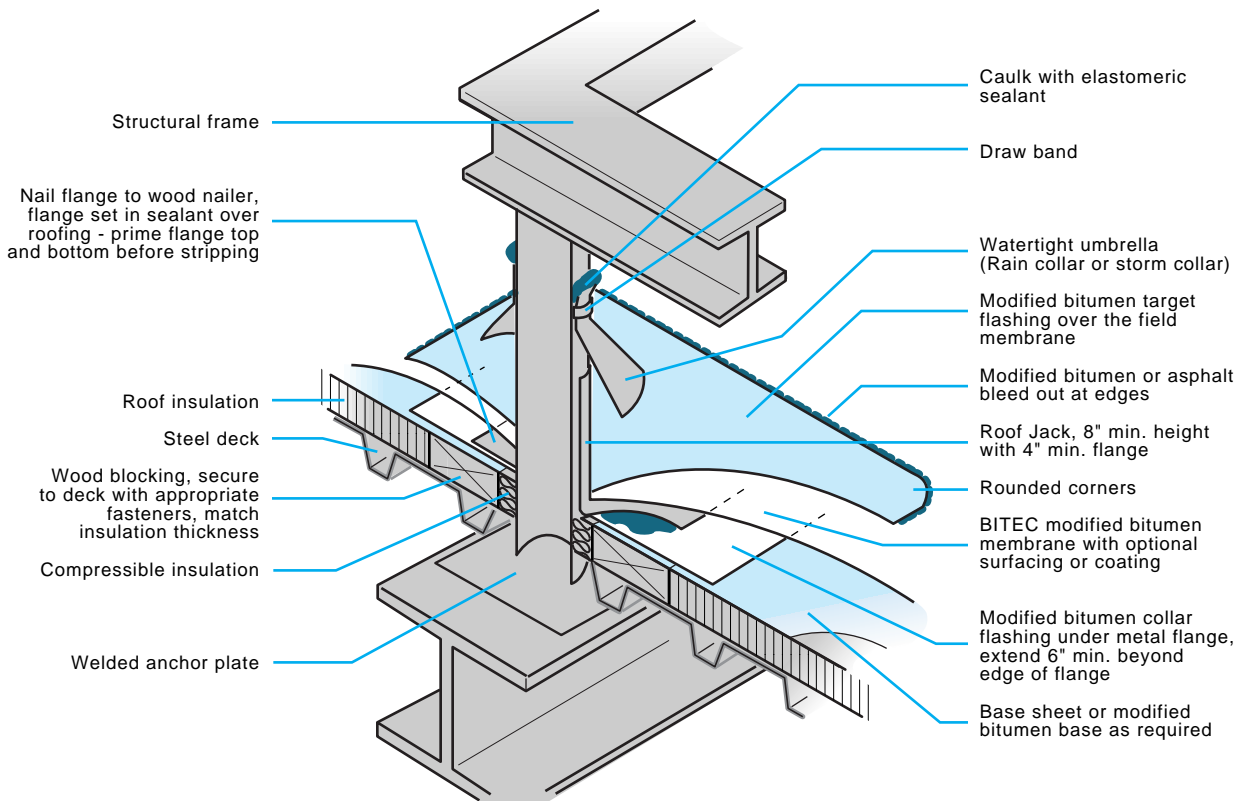

23. Concrete Deck Frame Support

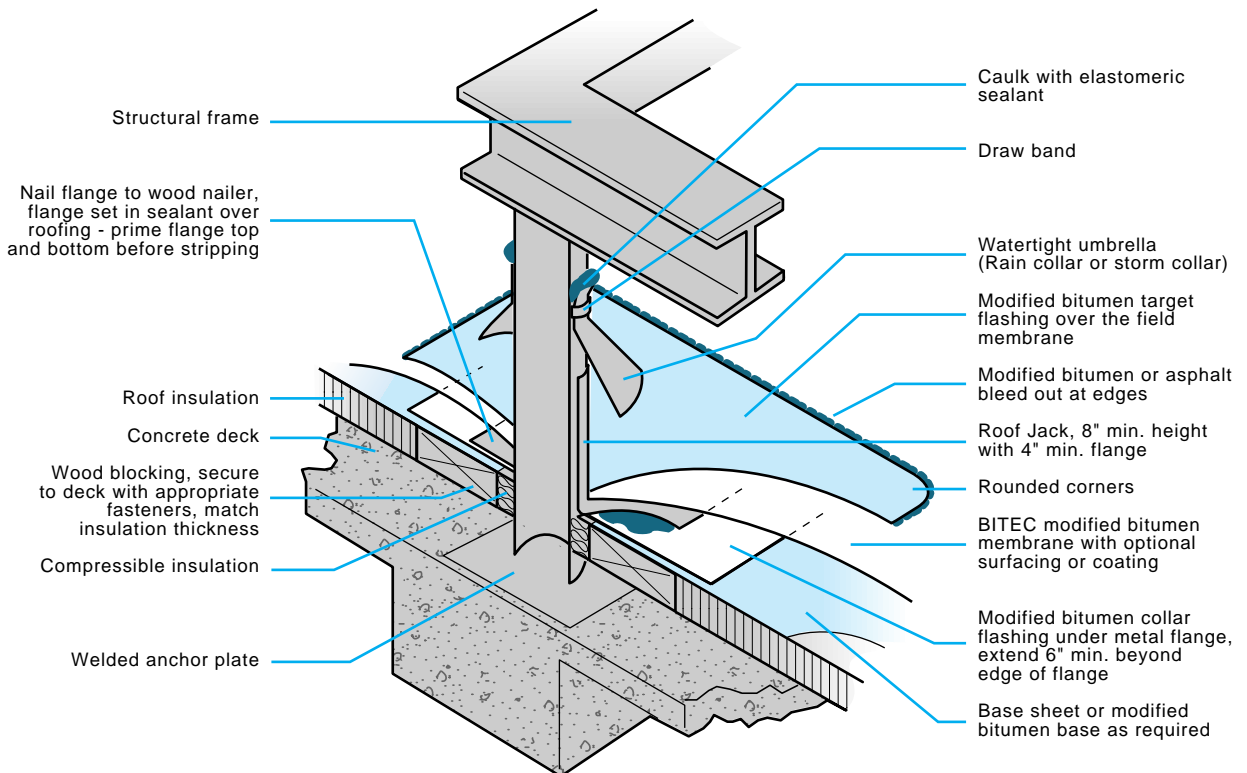

24. Pipe Support with Roller Assembly

This detail allows for expansion and contraction of pipes without damage to the roof.

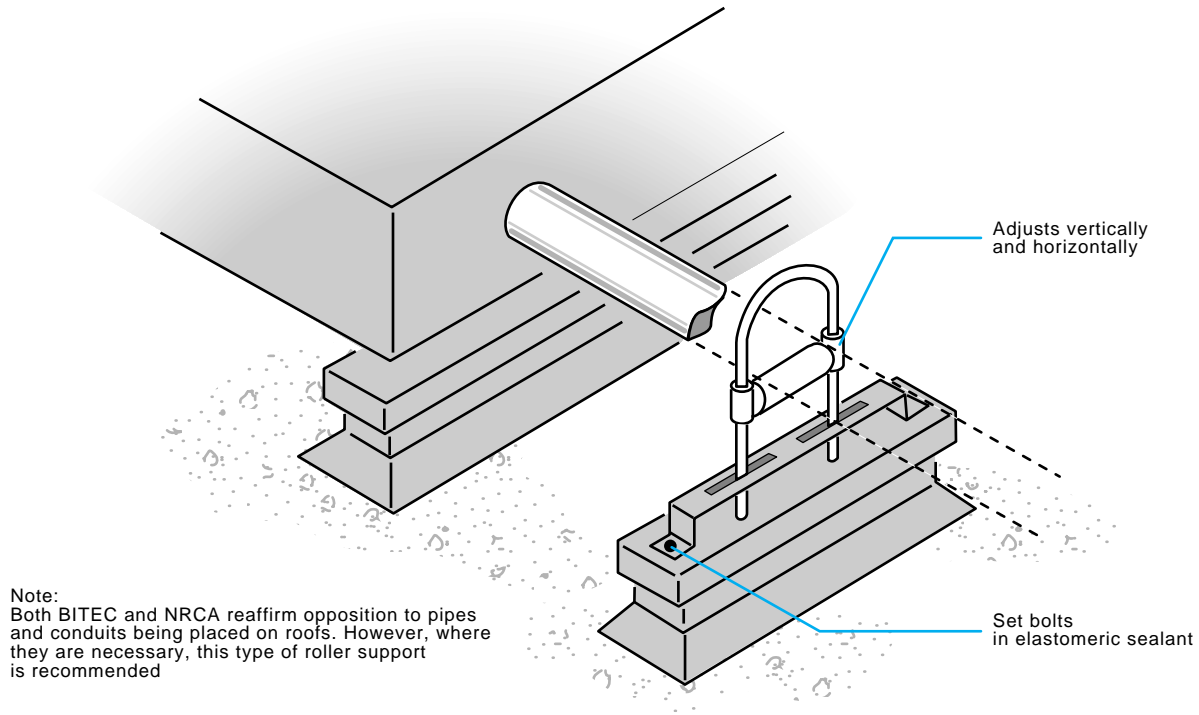

25. Equipment or Sign Support Rail

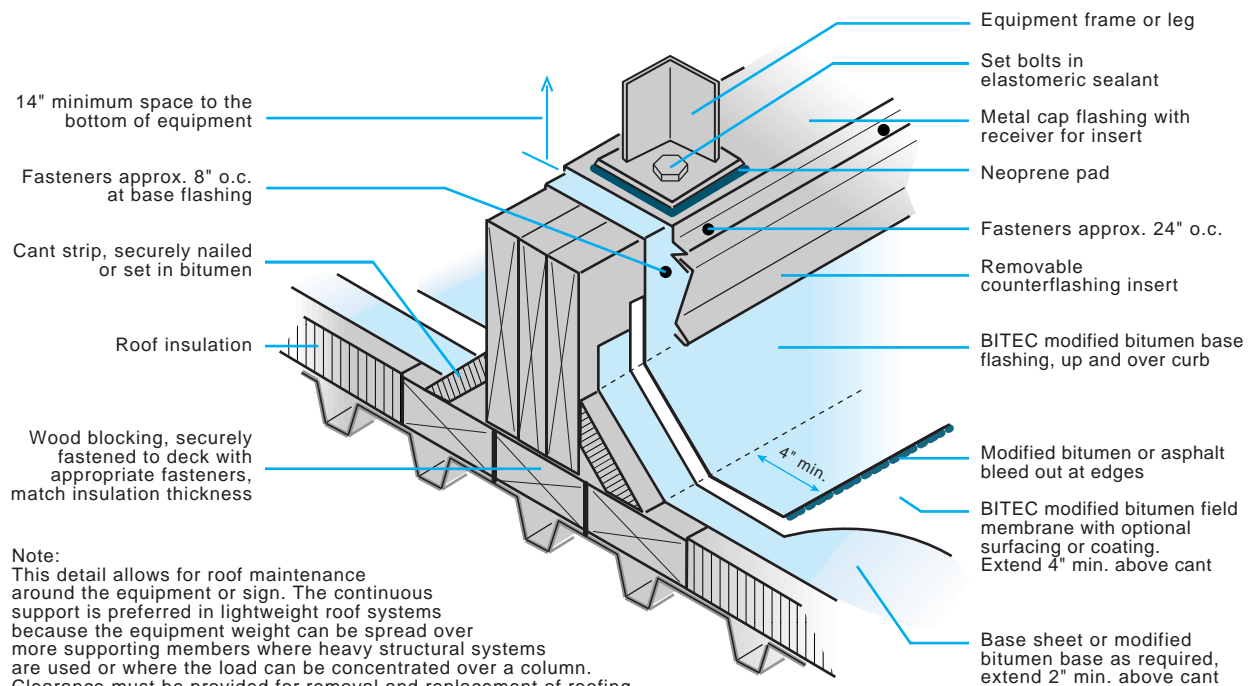

26. Pipe and Flashing Clearances

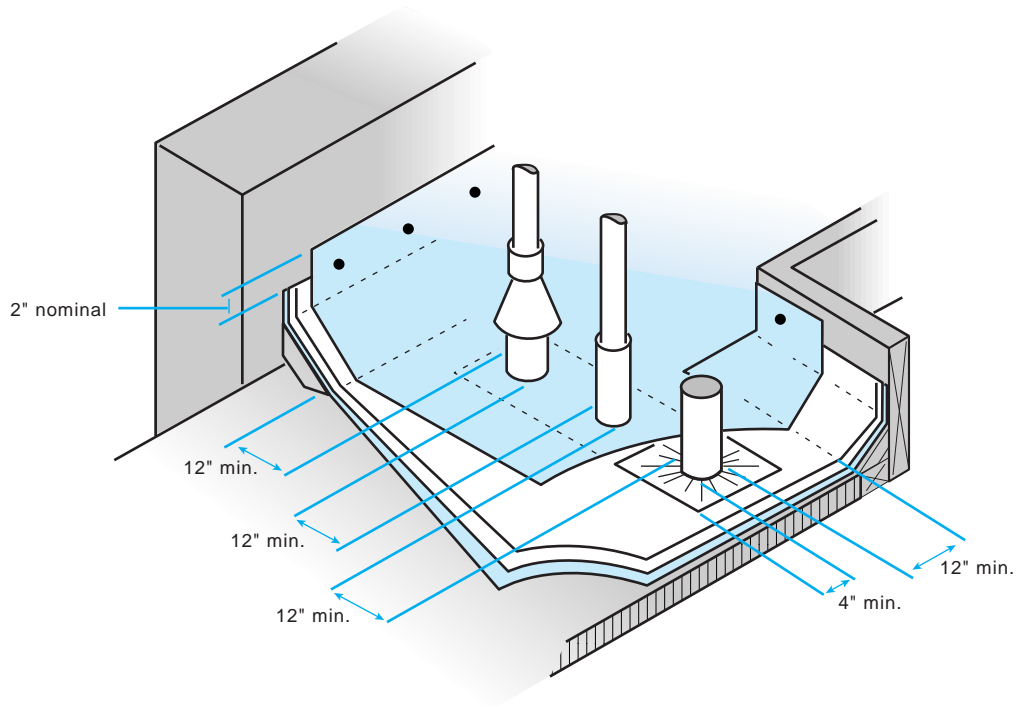

27. Mechanical Equipment Stand

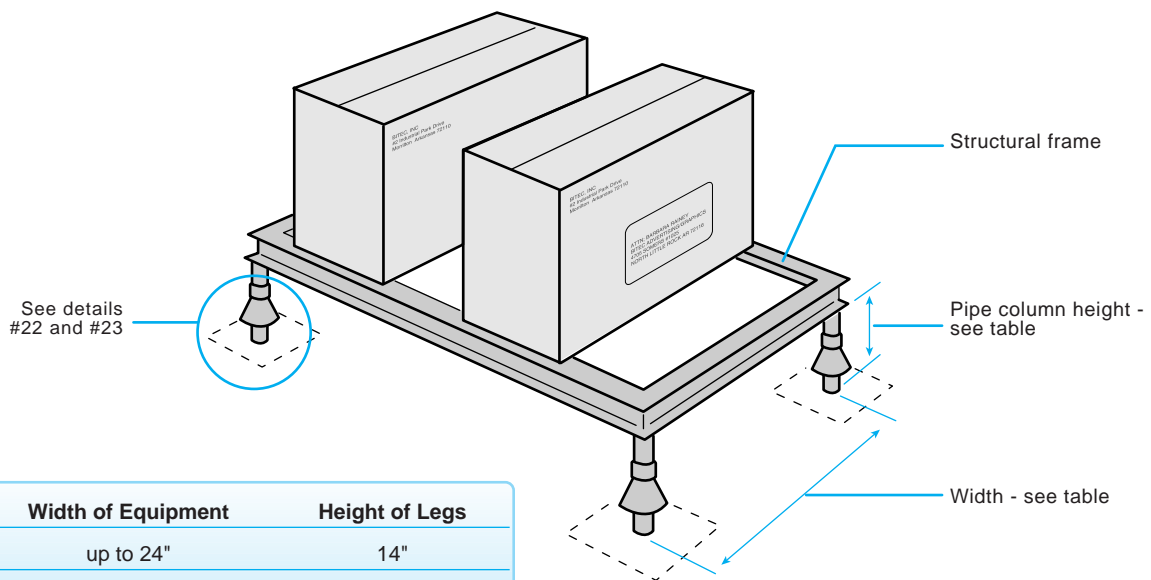

Width of Equipment	Height of Legs
up to 24"	14"
25 to 36"	18"
37 to 48"	24"
49 to 60"	30"
61" and wider	48"

Note:
This detail is preferable when the concentrated load can be located directly over columns or heavy girders in the structure of the building. This detail can be adapted for other uses, such as sign supports.

28. Plumbing Vent Flashing

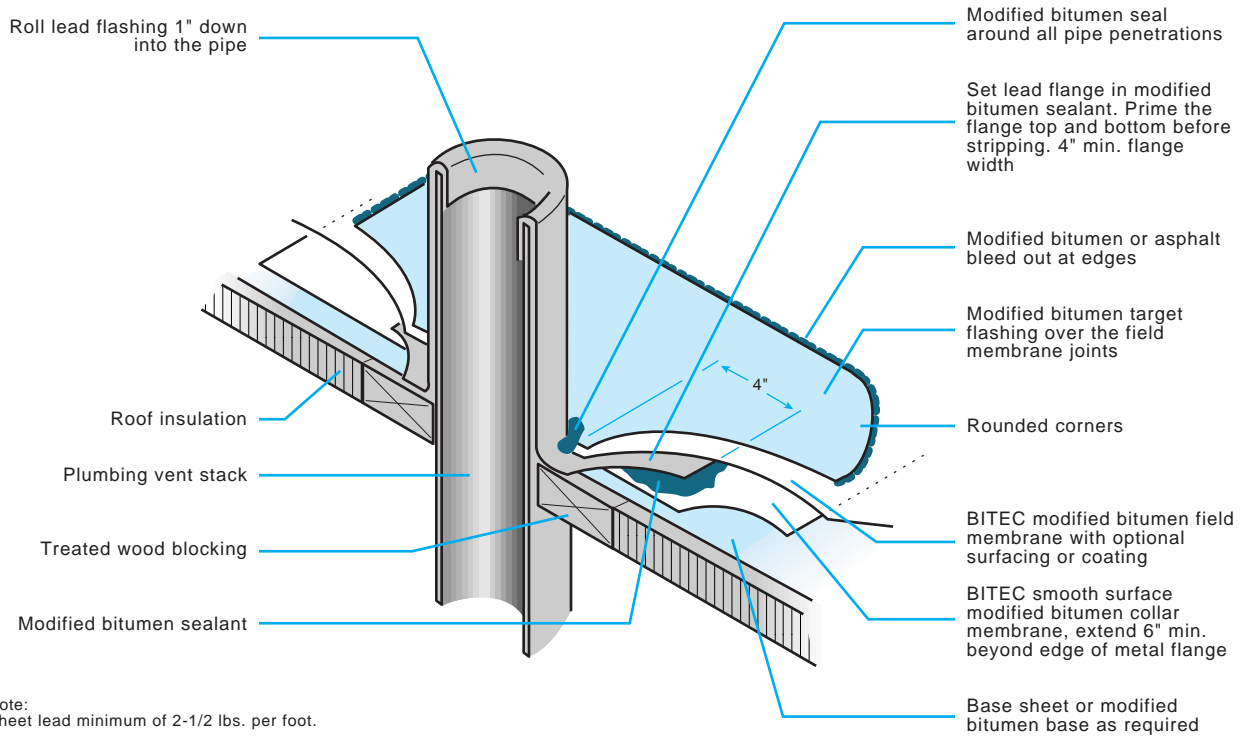

29. Approved One-Way Roof Vent

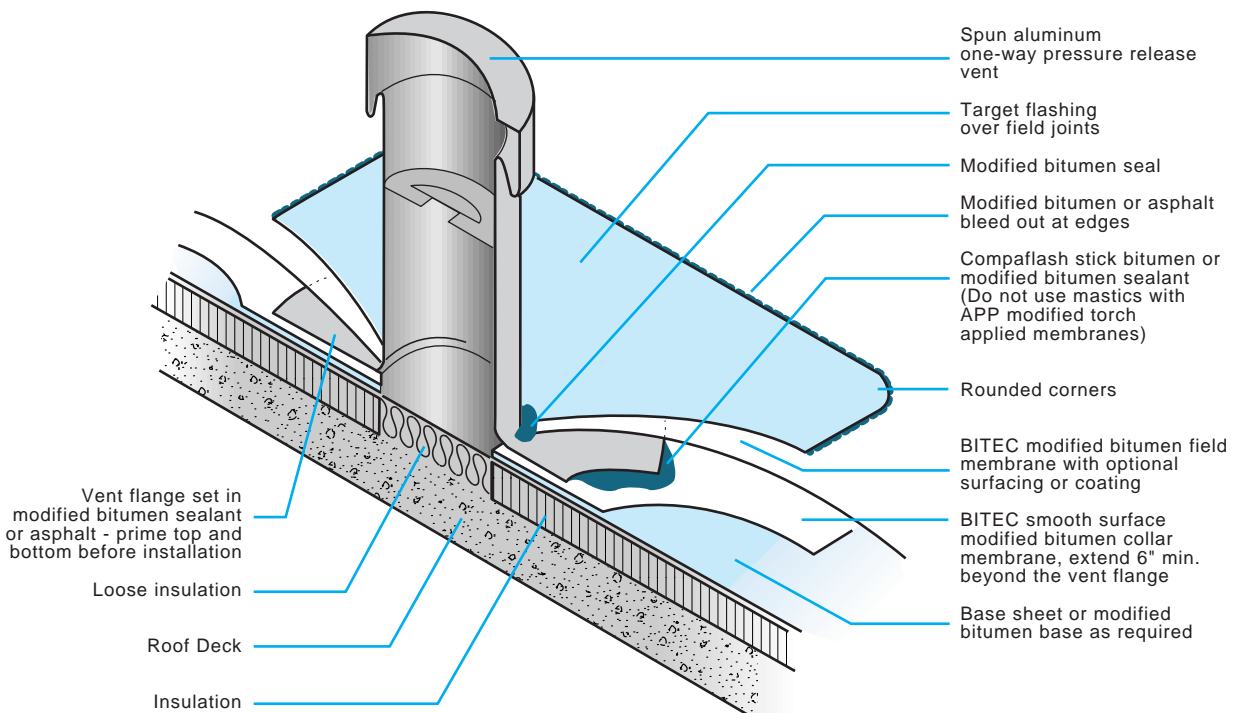

30. Hot Stack Flashing Curb

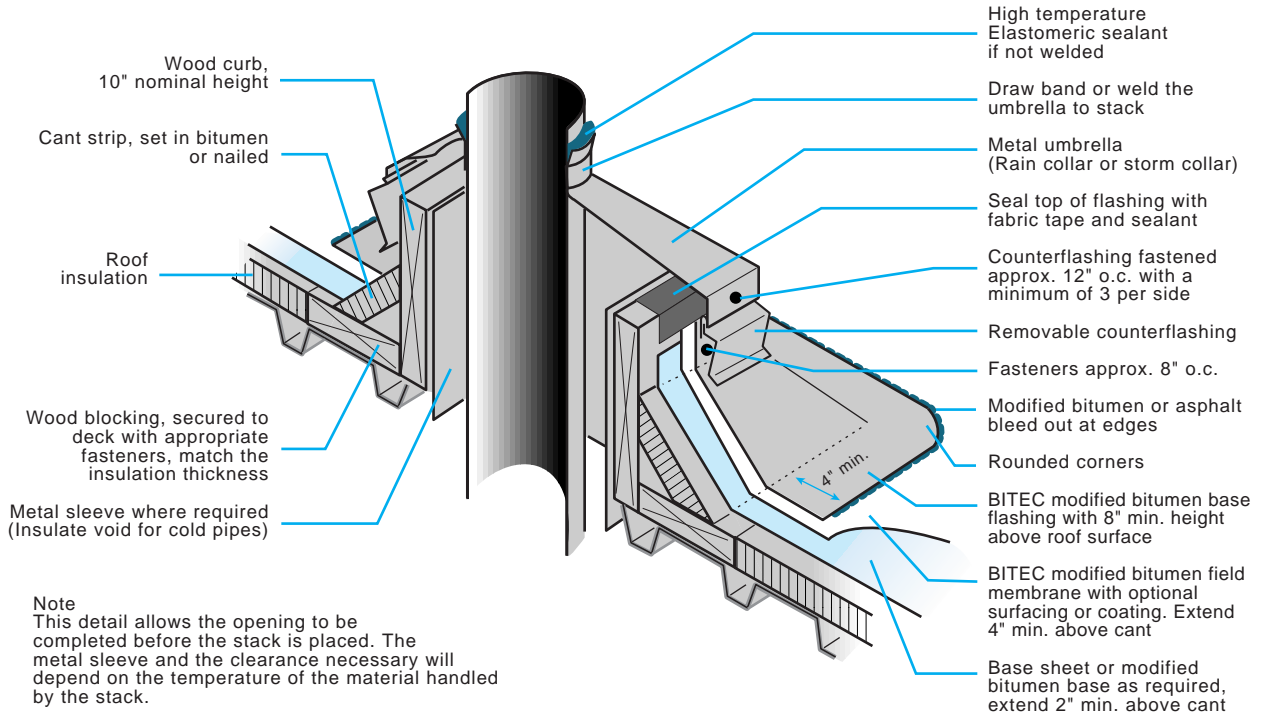

31. Piping Through Roof Deck

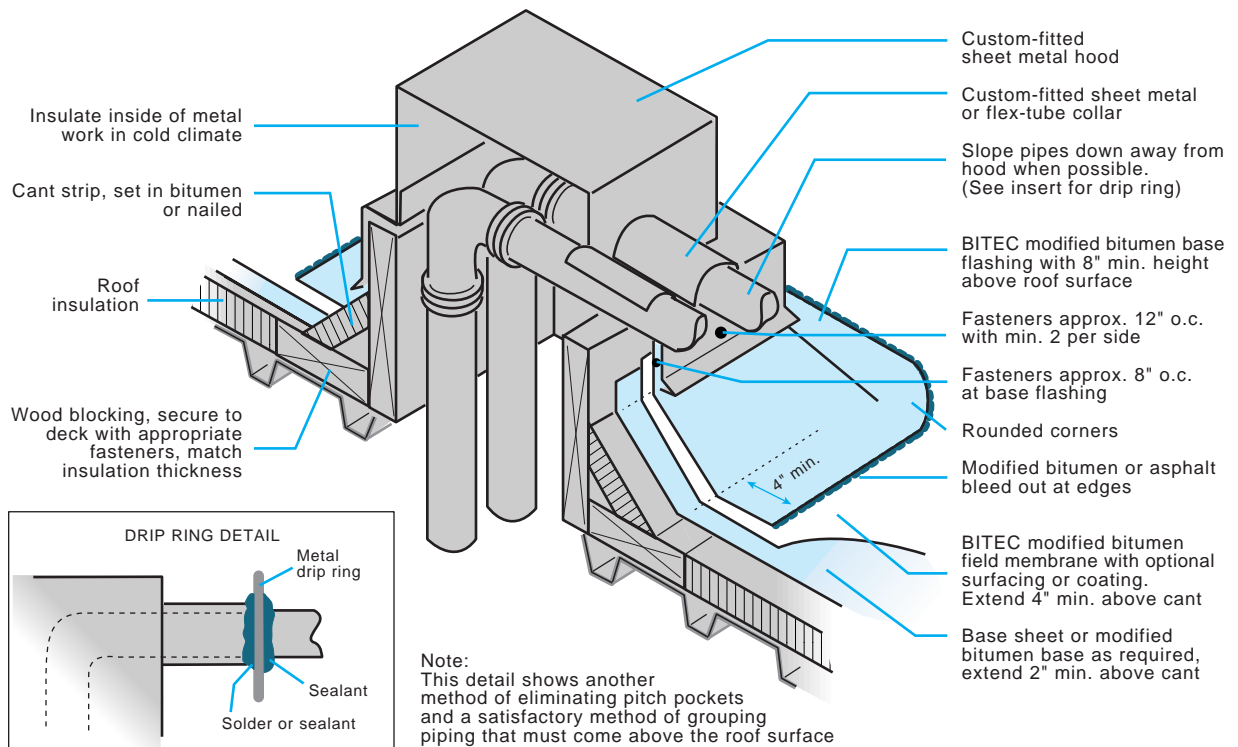

32. Typical Pitch Pan

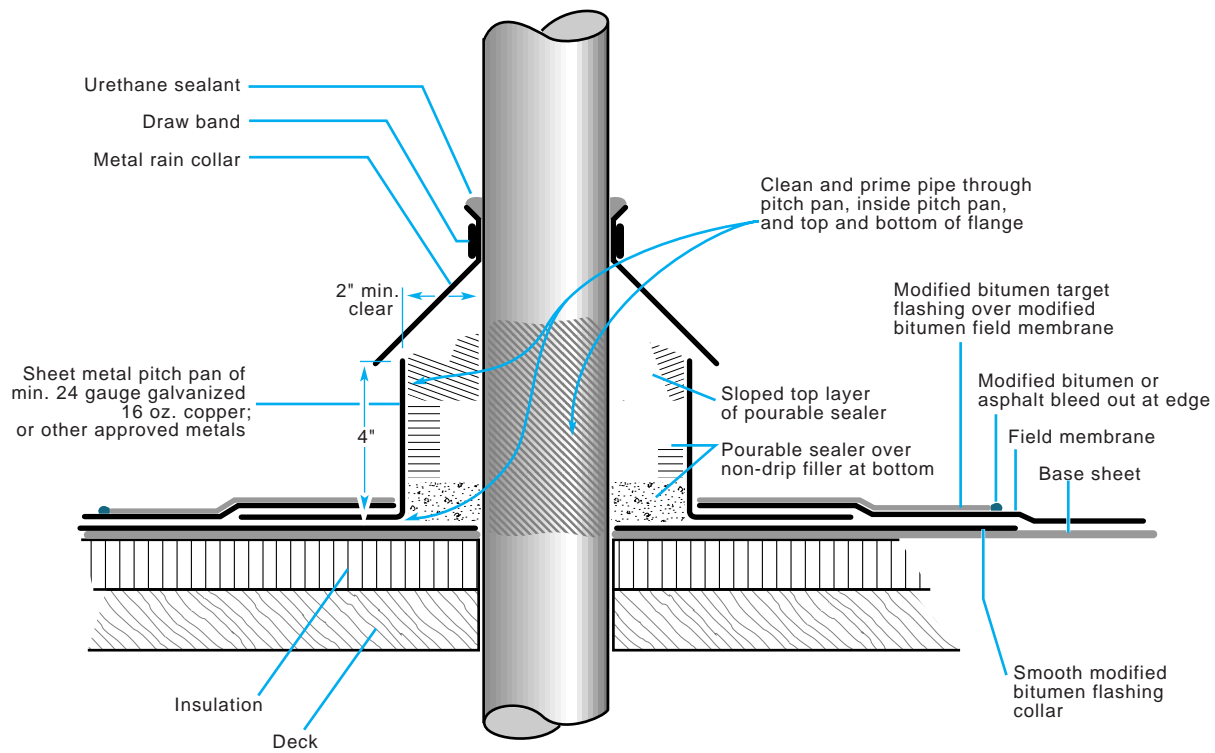

33. Split Repair

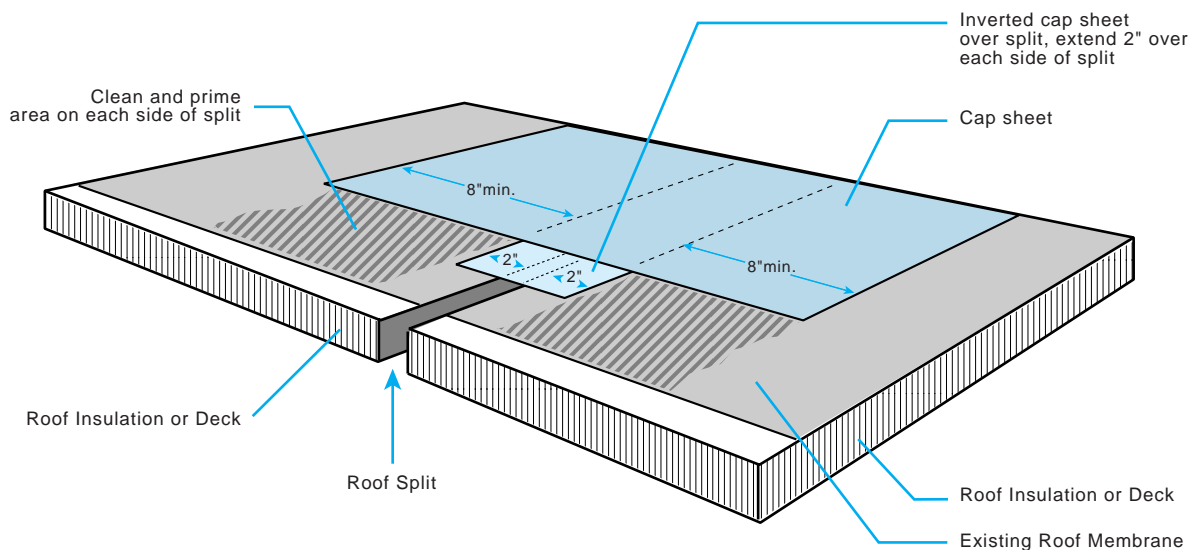

Clean area to be repaired of any coatings or loosed surfacing granules; spud any gravel to a clean, smooth surface. Prime area to be repaired and allow to dry thoroughly. Cut a strip of SPM series, APM-4T or APM-4.5T cap sheet to extend 2" each side of split. Lay the piece dry, granule side down, over the split. (The use of lightweight cap sheets is not recommended.)

Using material compatible with the existing roof, cut a strip of SPM series, APM-4T or APM-4.5T cap sheet to extend 8" min. each side of the DRY piece. Adhere in hot asphalt or torch into place as required for material being used.

APP or SBS cap sheets may be used over asphalt built up roofs.

ROOF ASSEMBLY GENERAL REQUIREMENTS

- 1) Systems warranted for 15 or 20 years require complete removal of all existing roofing and insulation, if not new construction.
- 2) NDL & Full System warranties require pre-approval, and complete removal of all existing roofing and insulation if not new construction.
- 3) Twelve (12) year warranted systems over wood decks will require one or more of the following:
 - a. Minimum $\frac{3}{4}$ " tongue and groove plywood decking.
 - b. A $\frac{1}{2}$ " minimum layer of roof insulation, $\frac{1}{2}$ " gypsum board or $\frac{1}{4}$ " Dens-Deck as a separation layer.
 - c. Minimum slope of $\frac{1}{4}$ " per foot.
- 4) Twelve (12) year warranted SBS systems with mechanically fastened base sheets will require one additional mopped ply of UL Type IV fiberglass ply sheet as an interply; with or without insulation.
- 5) Recover insulation is required over all previously graveled roofs or single ply roofs when pre-approved.
- 6) Mechanically fastened base sheets over existing smooth surface roofs (non-graveled) will be allowed only when pre-approved by BITEC's Technical Service Department.
- 7) One-way deck vents are required with all recover systems, concrete decks, gypsum decks and decks using all types of lightweight insulating fills.
- 8) Roof insulation may not be installed in direct contact with any lightweight concrete or gypsum decks. A vapor retarder must first be mechanically fastened to the deck, with any insulation adhered to the vapor retarder in hot asphalt.
- 9) **Metal base flashings are not acceptable.**
- 10) Maximum height for base flashings is 24". Any flashings above that height are considered "wall coverings" and are not covered by warranty.
- 11) Always refer to most recent UL, FM or other code agency listings or approvals for specific requirements which are not listed in this manual. Assemblies shown on the following pages are for BITEC warranty compliance, not necessarily for code agency compliance. All requirements are subject to change without notice.
- 12) Direct application of any BITEC product over an existing membrane without a base sheet and/or recover layer of insulation is not acceptable.
- 13) Cold applied systems **require** $\frac{1}{4}$ " :12 minimum slope for warranty.
- 14) **Maximum warranty for cold applied adhesive systems is 10 years.**

LAYING PATTERNS DIAGRAMS

The following Laying Pattern Diagrams only show some typical assemblies. Modifications may be made to any of them to accommodate many other situations. (See BUR-MOD section, pgs. 59-68)

There are numerous combinations possible when considering the available deck types, insulation and membrane combinations. Interplies may be added to two ply systems shown without adversely affecting the UL classification for that assembly. For systems to be warranted, BITEC may or may not allow hybrid or modified systems allowed by other manufacturers.

Pre-approval is required from BITEC's Manager of Technical Services for any extended warranty (over 12 years) or for any systems or assemblies considered unusual or questionable by BITEC.

Cold adhesive may not be used for multi-ply systems requiring more than two plies and consequently ten (10) years is the maximum warranty period for these systems. Cold adhesives may not be used with any APP membrane or SBS systems designed for torch application. Plastic cement must not be used with any BITEC modified bitumen product.

Vapor retarder systems are not shown on any of these diagrams because BITEC neither designs or warranties vapor retarder systems. Several conditions requiring vapor retarders are not warrantable by BITEC, such as swimming pools, freezer and cold storage buildings, and buildings with interior high humidity conditions.

In some instances, a barrier board of minimum $\frac{5}{8}$ " gypsum board or $\frac{1}{4}$ " Dens-Deck may be substituted

for the roof insulation board for warranty purposes. Pre-approval will be required. Under no circumstances will BITEC allow direct attachment by torching or mopping to the barrier board materials. All membranes must be mechanically fastened over these materials.

Refer to individual insulation manufacturer's FM Approvals and/or UL Listings for proper attachment to various decks. Fastening pattern requirements vary considerably for different types of insulation and thicknesses, and may change without notice.

Warranty requests must be submitted for pre-approval before installation of the membrane begins. Without prior approval, warranties may be denied.

1. Typical Three-Ply System Over Insulation

For 15 and 20 year systems

1. **Approved Roof Insulation** attached per specifications, over suitable substrate; required for 15 or 20 year systems.
2. **UL Type G2 Fiberglass Base Sheet** installed as per specification in hot asphalt.
3. **BITEC Smooth APP or SBS Interply Sheet** applied according to specification for particular system application.
4. **BITEC APP or SBS Cap Sheet** applied according to specification for the particular cap sheet application.
5. **Approved Roof Coating** required on APS-4T. Roof coating may be required on mineral surfaced membranes for UL and FM compliance. Gravel surfacing is required for warranty on SPS-3H membrane. A warranty fee is required for all 15 & 20 year systems.

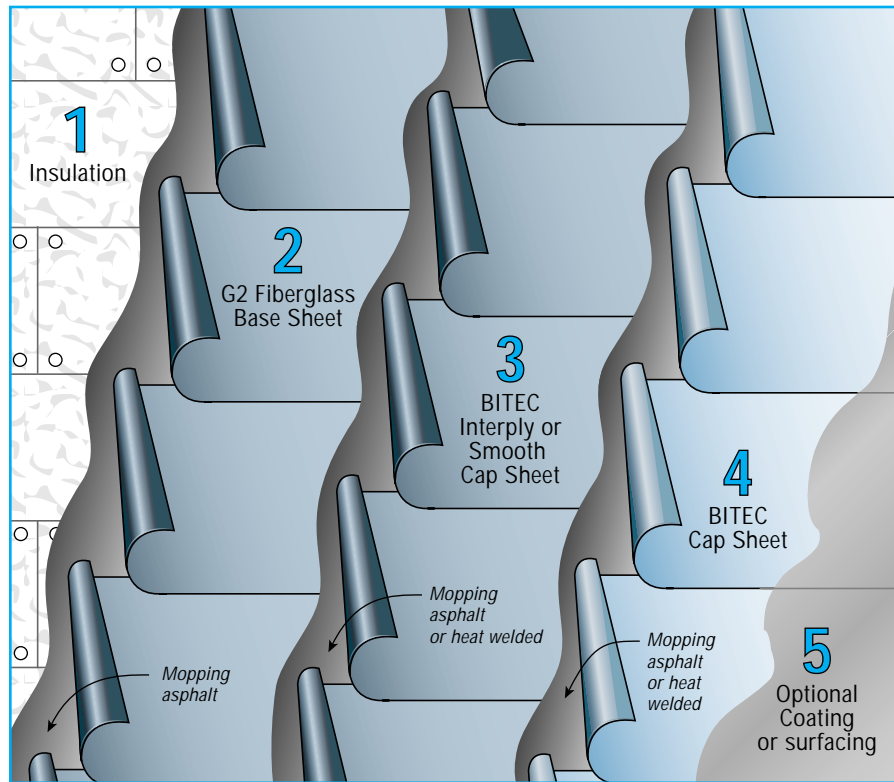

2. 3-Ply System, Mech. Attached Base Sheet & Insulation

For 15 or 20- year Systems.

1. **Approved Insulation** attached per specifications, over suitable substrate for 15 or 20 year systems.
2. **UL Type G2 Base Sheet** fastened through insulation to deck with appropriate fasteners and plates, 12" o.c. at base sheet laps and one row 12" o.c. along center of sheet.
3. **Bitec Smooth APP or SBS Interply Sheet** applied according to specification for particular cap sheet application
4. **Bitec APP or SBS Cap Sheet** applied according to specification for particular cap sheet application.
5. **Approved Roof Coating** required on APS-4T. Roof coating may be required on mineral surfaced membranes for UL and FM compliance. Gravel surfacing is required for warranty on SPS-3H membrane. A warranty fee is required for all 15 & 20 year systems.

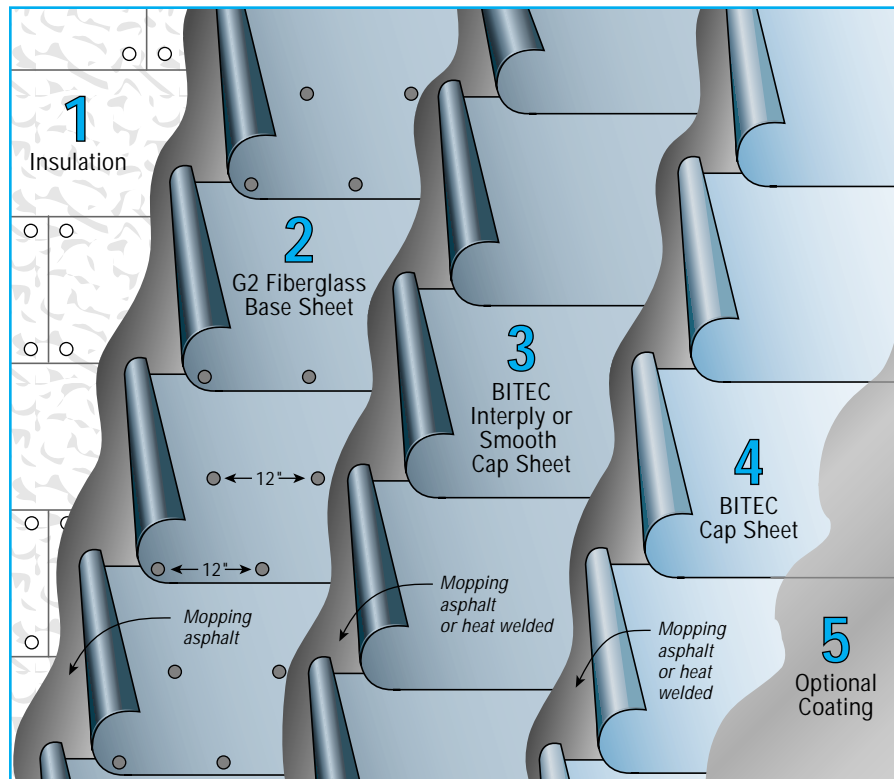

3. Mechanically Attached Base Sheet & Insulation

12 yr. max. warranty as shown for APP systems. 10 yr. max. warranty as shown for SBS; For 12 yr. warranty w/SBS systems, an add'l interply (not shown) of Type IV ply sheet is req'd.

1. Approved Roof Insulation over suitable substrate, pre-secured per FMRC requirements.

2. UL Type G2 Fiberglass Base Sheet fastened through insulation to deck with appropriate fasteners and plates, 12" o.c. at base sheet laps and one row 12" o.c., down center of sheet.

3. BITEC APP or SBS Cap Sheet applied according to specification for particular cap sheet application.

4. Approved Roof Coating required on SPS-3H; optional on APS-4T for 10 years, required for 12 years. Coating may be required on mineral surfaced membranes for UL or FM compliance. A warranty fee is required for uncoated APS-4T for 10 years.

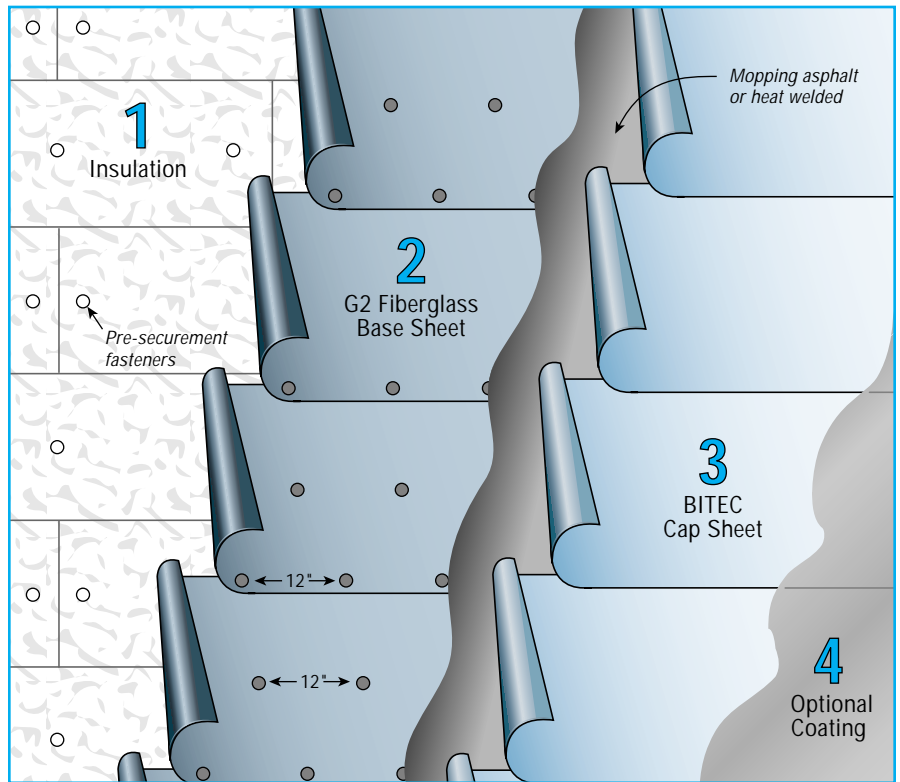

4. Nailable Deck, without Insulation

10 year maximum warranty

1. UL Type G2 Fiberglass Base Sheet or Vented Base Sheet or an inverted G3 Fiberglass cap sheet fastened over suitable deck with appropriate fasteners and plates, 9" o.c. at base sheet laps and two rows 18" o.c. staggered, 11" apart down center of sheet.

2. BITEC APP or SBS Cap Sheet applied according to specification for particular cap sheet application.

3. Approved Roof Coating required on SPS-3H; optional on APS-4T. Coating may be required on mineral surfaced membranes for UL or FM compliance. A warranty fee is required for uncoated APS-4T.

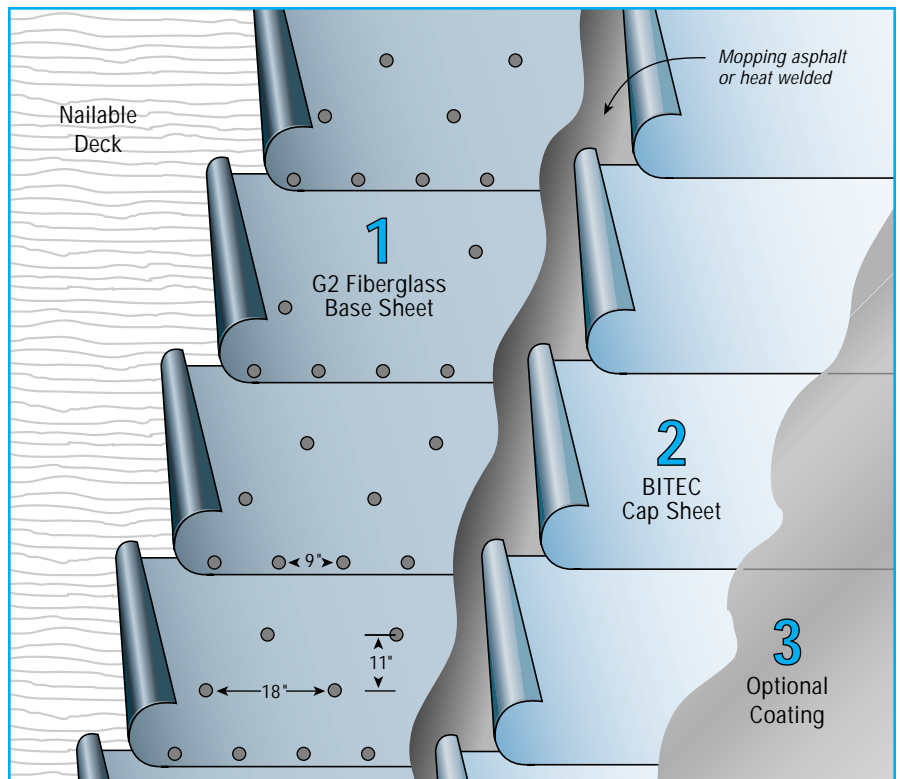

5. Nailable Lightweight Concrete Deck

12 yr. max. warranty for 3 ply system as shown. *A modified bitumen interply is required for 15 or 20 yr. systems; See specific system requirements.

1. **UL Type G2 Fiberglass Base Sheet** or Vented Base Sheet fastened with appropriate fasteners and plates; 9" o.c. at laps and 2 rows 11" apart down center of sheet, 18" o.c. staggered, or as required for FM approval.
2. **UL Type IV Fiberglass Ply Sheet** installed in a solid mopping of hot asphalt per specification. *A mod bit interply is required for 15 and 20 year systems.
3. **BITEC APP or SBS Cap Sheet** applied according to specification for particular cap sheet application.
4. **Approved Roof Coating** required on SPS-3H and APS-4T. Coating may be required on mineral surfaced membranes for UL or FM compliance. A warranty fee is required for 15 and 20 year warranties.
5. **One-Way Vents** required.

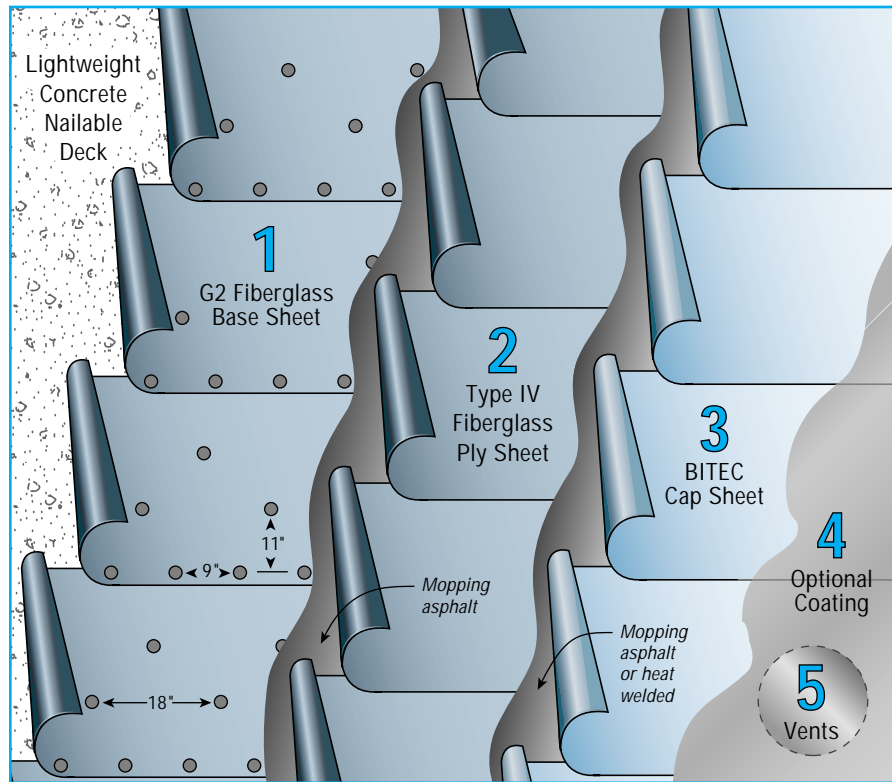

6. Concrete Deck, Fully Adhered

10 year or 12 year max. warranty for 2 ply system as shown. A modified bitumen interply (not shown) is req'd. for 15 and 20 year systems.

1. **Approved Insulation** installed in a solid mopping of hot asphalt, or mechanically fastened. Concrete deck must first be primed and allowed to thoroughly dry when asphalt is used.
2. **UL Type G2 Fiberglass Base Sheet** installed in a solid mopping of hot asphalt per specification.
3. **BITEC APP or SBS Cap Sheet** applied according to specification for particular cap sheet application.
4. **Approved Roof Coating** required on SPS-3H; optional on APS-4T for 10 years, required for 12, 15 and 20 years. Coating may be required on mineral surfaced membranes for UL or FM compliance. A warranty fee is required for 15 and 20 years.
5. **One-Way Vents** required over concrete decks.

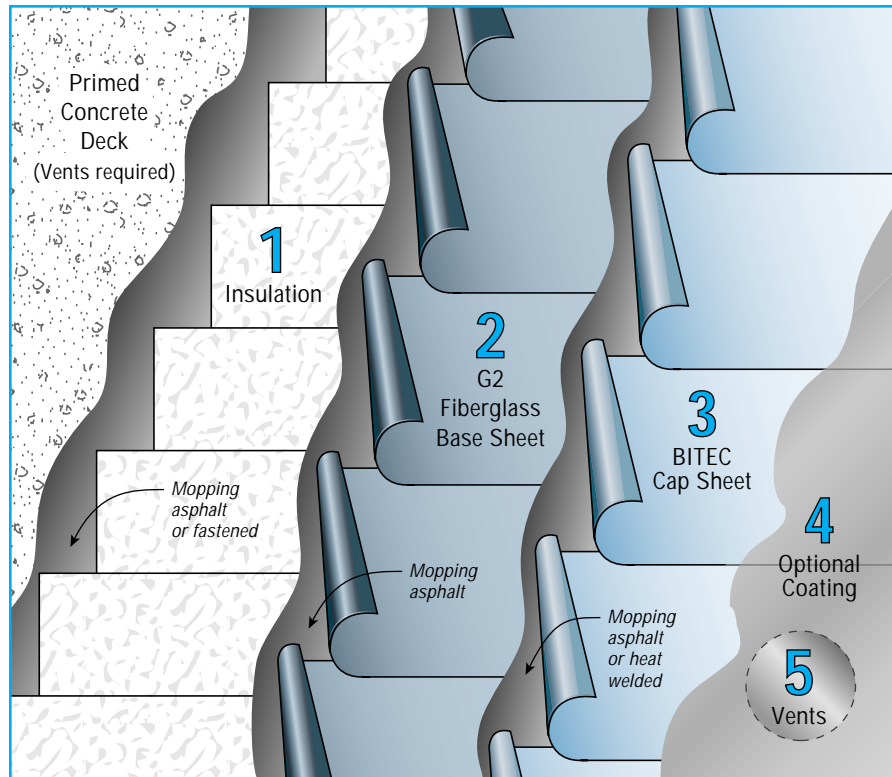

7. Mech. Attached Insulation, Mopped Base Sheet

12 Year maximum warranty for SBS or APP membranes

- 1. Approved Roof Insulation** attached per specification, over a suitable substrate.
- 2. UL Type G2 Fiberglass Base Sheet** installed as per specification in hot asphalt.
- 3. BITEC APP or SBS Cap Sheet** applied according to specification for particular cap sheet application.
- 4. Approved Roof Coating** required for all smooth surface sheets. Coating may be required on mineral surfaced membranes for UL and FM compliance. No warranty fee for 10 or 12 year systems. 10 year maximum warranty for uncoated APS-4T; a warranty fee is required.

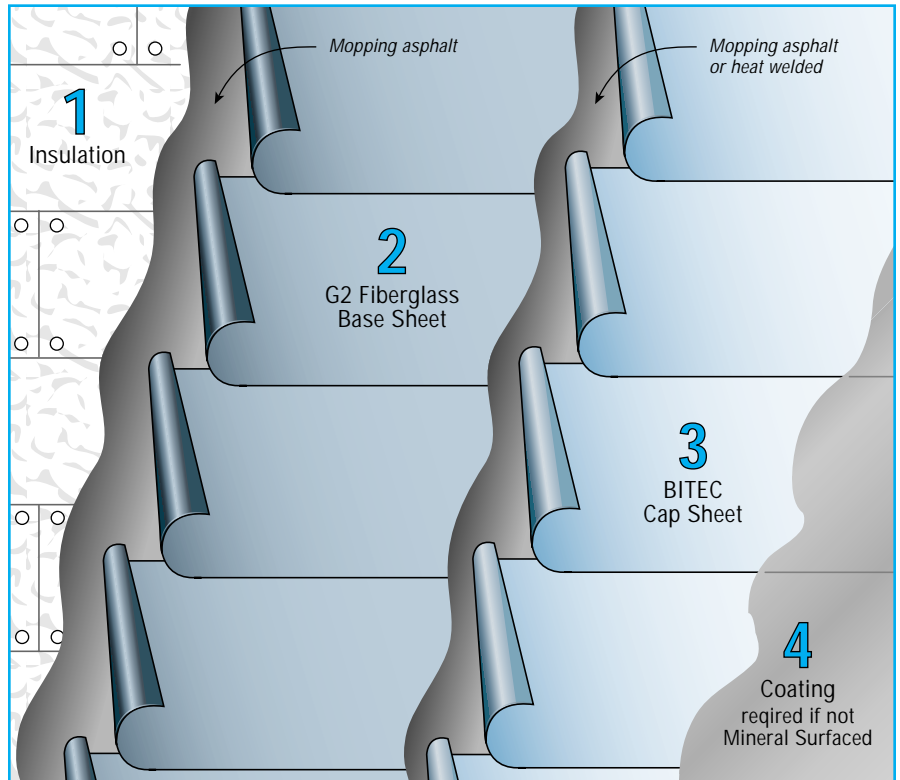

8. Typical Re-Cover System

10 year or 12 year max. warranty is available. A 15 or 20 year warranty is not available without tear-off of existing assembly.

- 1. Approved Re-Cover Insulation** at least one layer (1/2" min. thickness), mechanically fastened with appropriate type and quantity of fasteners, suitable for deck and insulation board size.
- 2. UL Type G2 Fiberglass Base Sheet** installed in a solid mopping of hot asphalt.
- 3. BITEC APP or SBS Cap Sheet** applied according to specification for particular cap sheet application.
- 4. Approved Roof Coating** required for all smooth surface sheets. Coating may be required on mineral surfaced membranes for UL and FM compliance. No warranty fee for 10 or 12 year systems. 10 year maximum warranty for uncoated APS-4T; a warranty fee is required.
- 5. One-Way Vents** required.

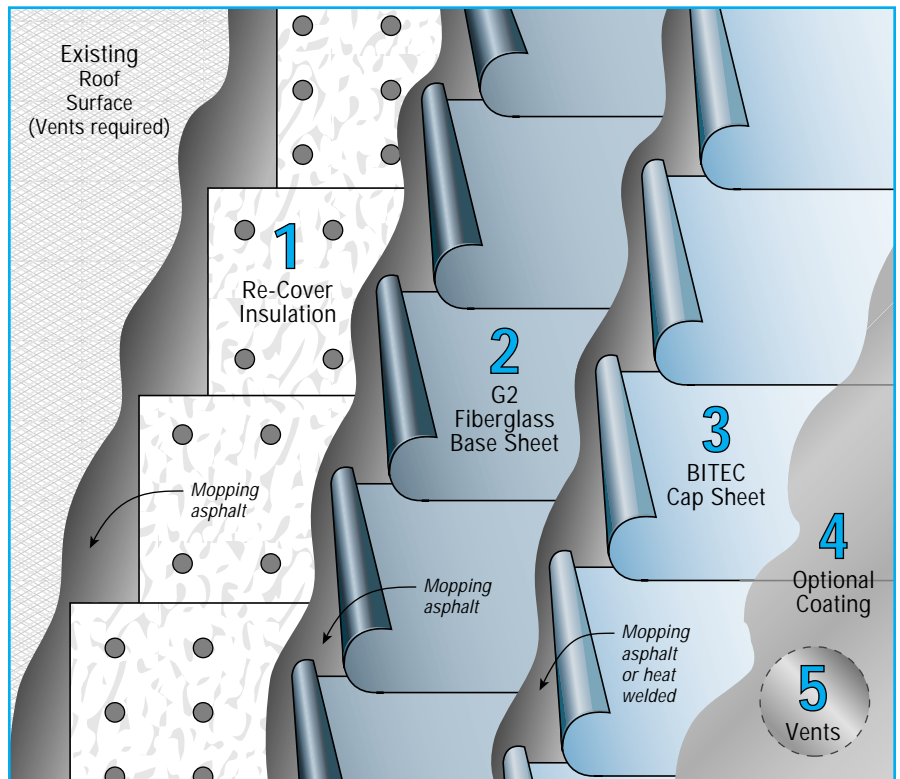

BUR-MOD SYSTEMS

SCOPE AND PURPOSE

To provide alternate roofing assemblies within our existing product lines, allowing for more economical systems within the guidelines of industry competition. The BITEC **BUR-MOD** assemblies offer system parity without compromising BITEC quality and reputation.

SYSTEM CONFORMANCE

Type IV and Type VI Ply sheets must conform to ASTM D2178-97a *Standard Specification for Asphalt Glass Felt Used in Roofing and Waterproofing*; and Classified G1 by Underwriters Laboratories, Inc.

G2 Base sheet must conform to ASTM D4601-97a *Standard Specification for Asphalt-Coated*

Glass Fiber Base Sheet Used in Roofing; and Classified G2 by Underwriters Laboratories, Inc.

BUR-MOD WARRANTIES

BITEC offers 10, 12, 15 and 20 year warranties for **BUR-MOD** systems. Provisions for NDL and FULL SYSTEM warranties are also available when pre-approved by BITEC's Manager of Technical Services. Warranty Request forms should be received on all projects prior to start of the roofing application for review and/or pre-approval by BITEC's Technical Services Department.

Warranty charges are subject to change without notice and are available by contacting your BITEC representative or the Technical Services Department.

IMPORTANT NOTICE

The roofing contractor, architect, specifier, or user of these systems must be familiar with all BITEC, INC. standard specifications for both Modified Bitumen systems and these hybrid systems which BITEC refers to as **BUR-MOD SYSTEMS**, for proper specification, detailing and installation.

Pertinent information may be found in other sections of this manual. Before starting any project using BITEC products, it is recommended that all publications relative to the project and BITEC products be consulted and understood.

Any questions should be directed to the BITEC Technical Services Dept. at (800) 535-8597.

BUR-MOD SECTION CONTENTS

Installation Parameters.....	60
Base Sheet and Ply Sheet Product Trade Names.....	61
Specification Numbers Chart	61
Typical BUR Systems, 3 and 4-ply	62-63
DETAIL DRAWINGS:	
#BM1Draining Edge with Gutter	64
#BM1aDraining Edge with Gutter, alternate	64
#BM2Flat Draining Edge (Drip Edge, Gravel Stop).....	65
#BM2aFlat Draining Edge (Drip Edge, Gravel Stop), alternate	65
#BM7Multi-Ply Base Flashing at Plywood Parapets	66
#BM7AHigh Parapet Base Flashing at Plywood Walls.....	66
#BM7BHigh Parapet Base Flashing at Masonry Walls	67
#BM7CMulti-Ply Base Flashing at Masonry Parapets.....	67
#BM28Plumbing Vent Flashing	68
#BM30Hot Stack Flashing Curb.....	68

NOTE: Lower case "a" designates an *alternate* detail, and upper case letters with detail numbers indicate *additional* similar details.

INSTALLATION PARAMETERS

SECTION 1.00

INSULATION

In all cases a minimum of 1/2" thick perlite or high density wood fiber board insulation will be installed as a buffering layer. Other insulations are acceptable for use within these systems provided the insulation manufacturer's specifications and BITEC's specifications are followed. See the General Requirements SECTION 6.02 of this manual.

Insulation must be used with all systems unless its use has been waived by BITEC's Technical Services Department.

SECTION 2.00

BASE SHEETS AND PLY SHEETS

Unless otherwise specified all base and ply sheets will be installed using hot asphalt as per BITEC's published requirements which determine the type of asphalt to be used, asphalt application rate, and asphalt application temperature. See the General Requirements SECTIONS 1.02, 1.03 and 1.04 of this manual.

Under no circumstances will any Type IV or Type VI Ply Sheet be mechanically attached. Under certain conditions, however, the G2 base sheet called for in the schedule may be mechanically attached.

Allowance for this must be pre-approved by BITEC's Technical Services Department. For parameters involving mechanically attaching G2 base sheets refer to SECTION 2.02, on pg.17 of this manual.

According to The NRCA Roofing and Waterproofing Manual:

"...plies shall be embedded into a fluid, continuous applica-

tion of asphalt. The asphalt shall be applied in such a way that at no place will felt touch felt. All plies of felt shall be broomed into place as they are applied to aid in adhesion ..."

SECTION 3.00

CAP SHEET

Cap sheet shall be installed as per specifications given in the General Requirements SECTIONS 2.03 and 2.04, pgs.17-18 of this manual.

SECTION 4.00

SPECIFICATIONS AND DETAILS

Primary consultation for this information shall come from this book, and *The NRCA Roofing and Waterproofing Manual*.

All applicable publications shall be consulted before work begins.

Some details for **BUR-MOD** systems are included in the following section of this manual. These details are simply variations of the details used for modified bitumen systems.

Typically, for **BUR-MOD** systems, all Modified Bitumen Details may be adapted to be used with **BUR-MOD** Systems.

This is generally accomplished by using the base and/or ply sheets in lieu of the base and/or interply membrane of the modified bitumen system.

For any specific details not shown, contact BITEC Technical Services Dept. at (800) 535-8597.

SECTION 5.00

ACCEPTABLE BASE AND PLY SHEET

Base sheet and ply sheet from the following companies are

acceptable for use within the BITEC **Bur-Mod** systems:

- 1) BITEC, INC.
- 2) TAMKO Roofing Prod., Inc.
- 3) Black Warrior Roofing, Inc.
- 4) Fields Corporation
- 5) Johns Manville (Schuller)

No other base or ply sheet shall be used other than those given above unless approval is granted from BITEC's Technical Service Department.

The above companies publish their compliance with standards for the products shown on the next page, Table 1.

SECTION 6.00

APPROVAL FOR USE OF BUR-MOD SYSTEMS AS A SUBSTITUTE FOR OUR STANDARD WARRANTY SYSTEMS

Pre-approval by the Technical Services Department is necessary in order to obtain a warranty for these systems.

All Warranty Requests must be submitted in a reasonable amount of time prior to the start of the project for pre-approval.

As is always done with any extraordinary warranty scenario, a special warranty document is used.

However, our standard Limited Insured Roofing Warranty is applicable for any of the following systems listed in Table 2, next page.

SECTION 7.00

SPECIFICATION NUMBERS

Specification number format will remain virtually the same with the following changes shown in chart on the next page.

APPROVED PRODUCTS - Base Sheet and Ply Sheet Product Trade Names

Company	Base Sheet (ASTM D 4601, Type II)	Type IV Ply Sheet (ASTM D 2178, Type IV)	Type VI Ply Sheet (ASTM D 2178, Type VI)
BITEC, INC.	BETA BASE	BETA PLY IV	BETA PLY VI
TAMKO Roofing Products, Inc.	GLASS-BASE	TAM-PLY IV	TAM-GLASS PREMIUM
Black Warrior Roofing, Inc.	Arrowglass Base	Arrowglass IV	Arrowglass VI
Fields Corporation	Fields F51	Fields F54	Fields F56
Johns Manville (Schuller)	GlasBase	GlasPly IV	GlasPly Premier
Johns Manville (Schuller)	PermaPly No. 28		PermaPly R

Table 1

SPECIFICATION NUMBERS

Warranty Period	Insulation Required?1st Ply2nd Ply3rd Ply4th PlySurfacingSpec Suffix
12 Years or Less	Yes4 or 64 or 6APS-4T	CoatingBM
	Yes4 or 64 or 6SPS-3H	CoatingBM
	Yes4 or 64 or 6Other*			
15 Years or Less	YesG26APS-4T	CoatingBM6
	YesG26SPS-3H	GravelBM6
	YesG26Other*		BM6
	YesG244APS-4TCoatingBM4
	YesG244SPS-3HGravelBM4
YesG244Other*	BM4	
20 Years or Less	Yes666APS-4TCoatingBM6
	Yes666SPS-3HGravelBM6
	Yes666APM-4T	BM6
	Yes666APM-4.5T	BM6
	Yes666SPM-4.5T	BM6
	Yes666SPM-3.5H	BM6
	Yes666SPM-4H/250	BM6
	Yes666SPM-4H	BM6
	YesG266APS-4TCoatingBMG
	YesG266SPS-3HGravelBMG
	YesG266APM-4T	BMG
	YesG266APM-4.5T	BMG
YesG266SPM-4.5T	BMG	
YesG266SPM-3.5H	BMG	

Other* = All other BITEC Cap Sheets except ISA-4T and EGM-2H.

Table 2

FOR EXAMPLE:

- SPM-3.5H.2.20.BMG** = SPM-3.5H.nailable situation.twenty year system.BUR-MOD G2 as base
- APS-4T.1.15.BM4** = APS-4T.non-nailable situation.fifteen year system.BUR-MOD Type IV as interply
- SPS-3H.2.12.BM** = SPS-3H.nailable situation.twelve year system.BUR-MOD Type IV or VI as base

BUR-MOD SYSTEMS

- 10 & 12 Year Systems -

1. Typical 3-Ply System 2 Ply Sheets, Cap Sheet

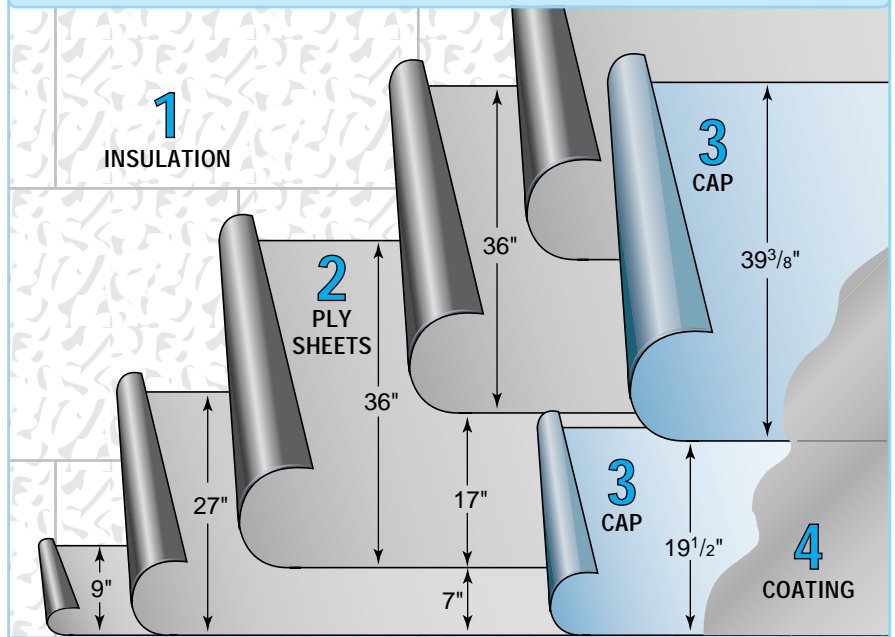

- 1. Approved Roof Insulation** attached per specifications, over suitable substrate.
- 2. Type IV or VI Fiberglass ply sheets (2 Plies)**, ASTM D2178-97a (UL Type G1), per specification requirement, installed in hot asphalt.
- 3. BITEC APP or SBS Cap Sheet** applied according to specification.
- 4. Approved Roof Coating** required for smooth surface sheets. Coating may also be required for any mineral surfaced membrane for compliance with UL & FM requirements. No warranty fee is required, except for NDL warranties.

- 20 Year System -

2. Typical 4-Ply System 3 Ply Sheets, Cap Sheet

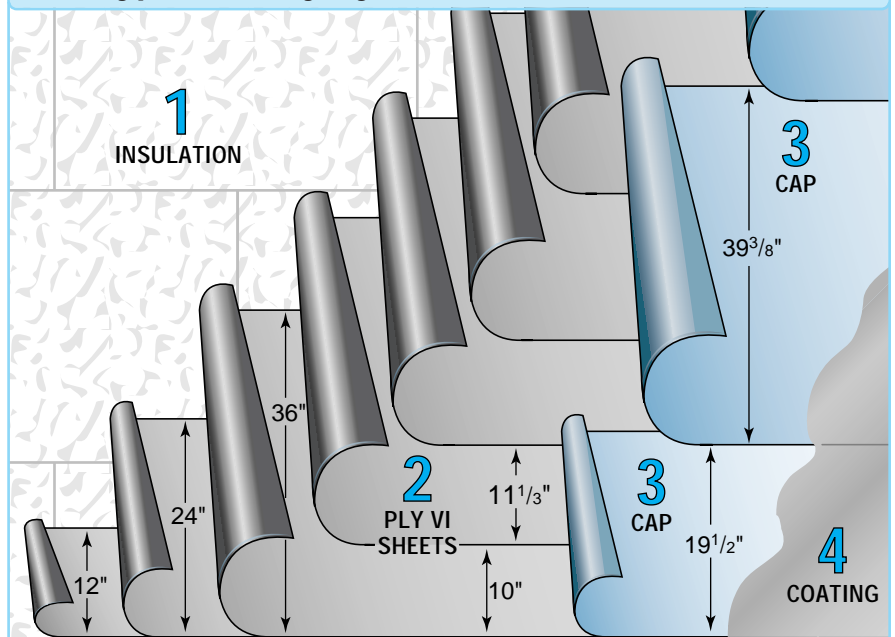

- 1. Approved Roof Insulation** attached per specifications, over suitable substrate.
- 2. Type VI Fiberglass ply sheets, (3 plies)** ASTM D2178-97a (UL Type G1), per specification requirement, installed in hot asphalt.
- 3. BITEC APP or SBS Cap Sheet** applied according to specification.
- 4. Approved Roof Coating** required for smooth surface APS-4T. Coating may also be required for any mineral surfaced membrane for compliance with UL & FM requirements. Smooth surface SPS-3H must be surfaced with a flood coat of hot asphalt and ASTM D1863-93 roofing gravel. A warranty fee is required.

APPLICATION OF PLYS: Embed all plies using ASTM D312 Type III or Type IV asphalt. Application rate of 25 lb/sq. is essential. Application of asphalt must provide a

continuous and uninterrupted layer of asphalt to which all plies are to be embedded. In no area should asphalt be applied as to allow felt to touch felt.

BUR-MOD SYSTEMS

1. Approved Roof Insulation attached per specifications, over suitable substrate, required for 15 year systems, except on lightweight insulating concrete decks.

2. UL Type G2 Fiberglass Base Sheet installed as per specification, either in hot asphalt or mechanically attached.

3. Type VI Fiberglass ply sheets, ASTM D2178-97a (UL Type G1), per specification requirement, installed in hot asphalt.

4. BITEC APP or SBS Cap Sheet applied according to specification.

5. Approved Roof Coating required for smooth surface APS-4T. Coating may also be required for any mineral surfaced membrane for compliance with UL & FM requirements. Smooth surface SPS-3H must be surfaced with a flood coat of hot asphalt and ASTM D1863-93 roofing gravel. A warranty fee is required.

- 15 Year Systems -

3. 3-Ply with Base Sheet 1 Base Ply, 1 Ply Sheet, Cap Sheet

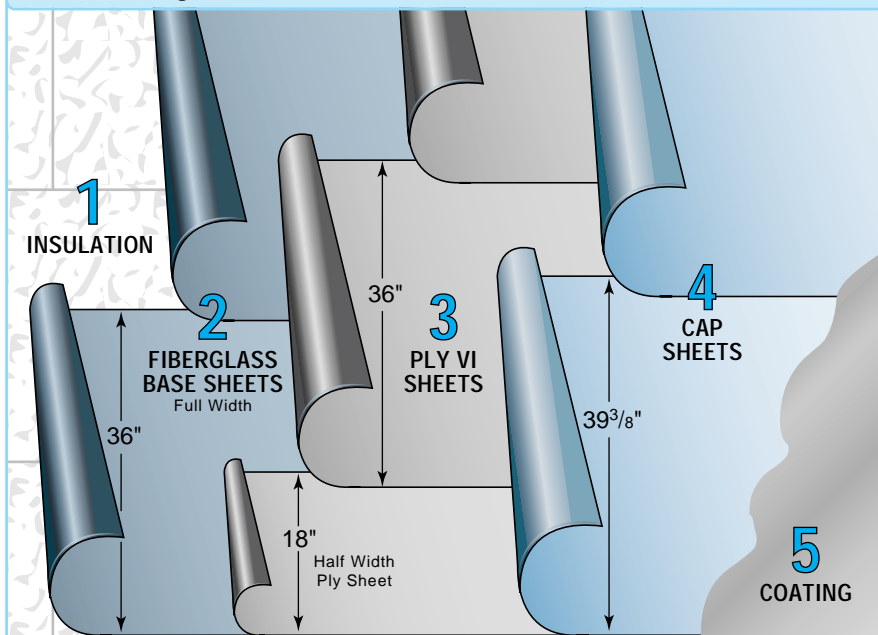

1. Approved Roof Insulation attached per specifications, over suitable substrate, required for 15 or 20 year systems, except on lightweight insulating concrete decks.

2. UL Type G2 Fiberglass Base Sheet installed as per specification, either in hot asphalt or mechanically attached.

3. Type IV or Type VI Fiberglass ply sheets, ASTM D2178-97a (UL Type G1), 2 plies, per specification requirement, installed in hot asphalt. Type IV for 15 year systems; Type VI for 20 year systems.

4. BITEC APP or SBS Cap Sheet applied according to specifications.

5. Approved Roof Coating required for smooth surface APS-4T. Coating may also be required for any mineral surfaced membrane for compliance with UL & FM requirements. Smooth surface SPS-3H must be surfaced with a flood coat of hot asphalt and ASTM D 1863-93 roofing gravel. A warranty fee is required.

- 15 & 20 Year Systems -

4. 4-Ply with Base Sheet 1 Base Ply, 2 Ply Sheets, Cap Sheet

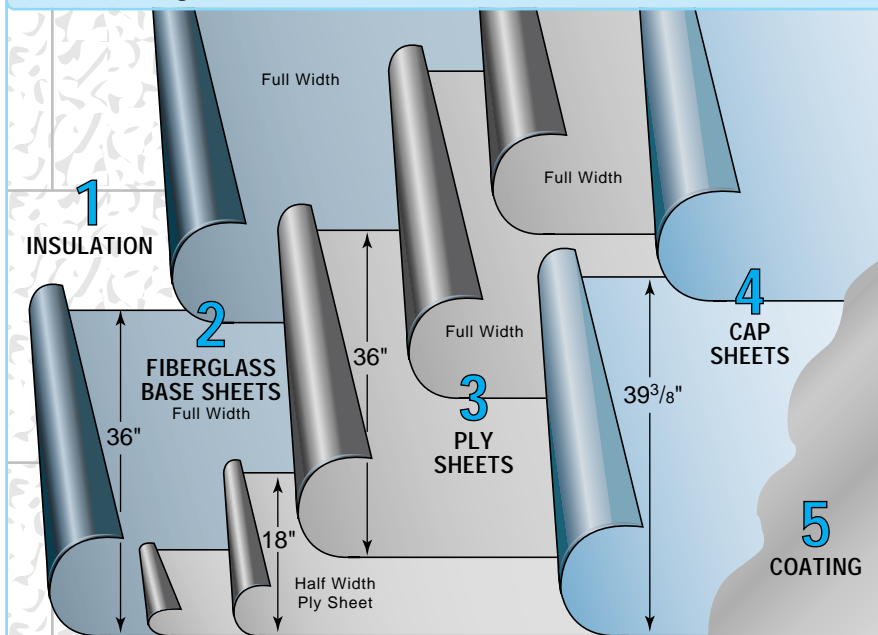

APPLICATION OF PLYS: Embed all plies using ASTM D312 Type III or Type IV asphalt. Application rate of 25 lb/sq. is essential. Application of asphalt must provide a

continuous and uninterrupted layer of asphalt to which all plies are to be embedded. In no area should asphalt be applied as to allow felt to touch felt.

BUR MOD 1. Draining Edge with Gutter

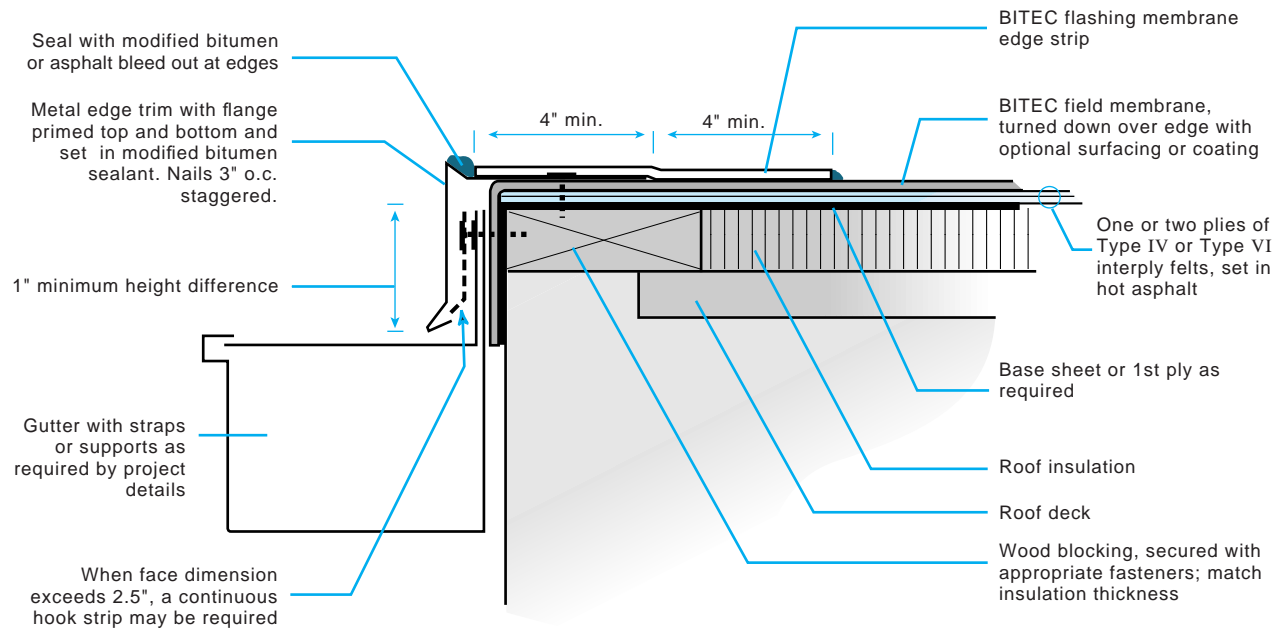

BUR MOD 1a. Draining Edge with Gutter, alternate

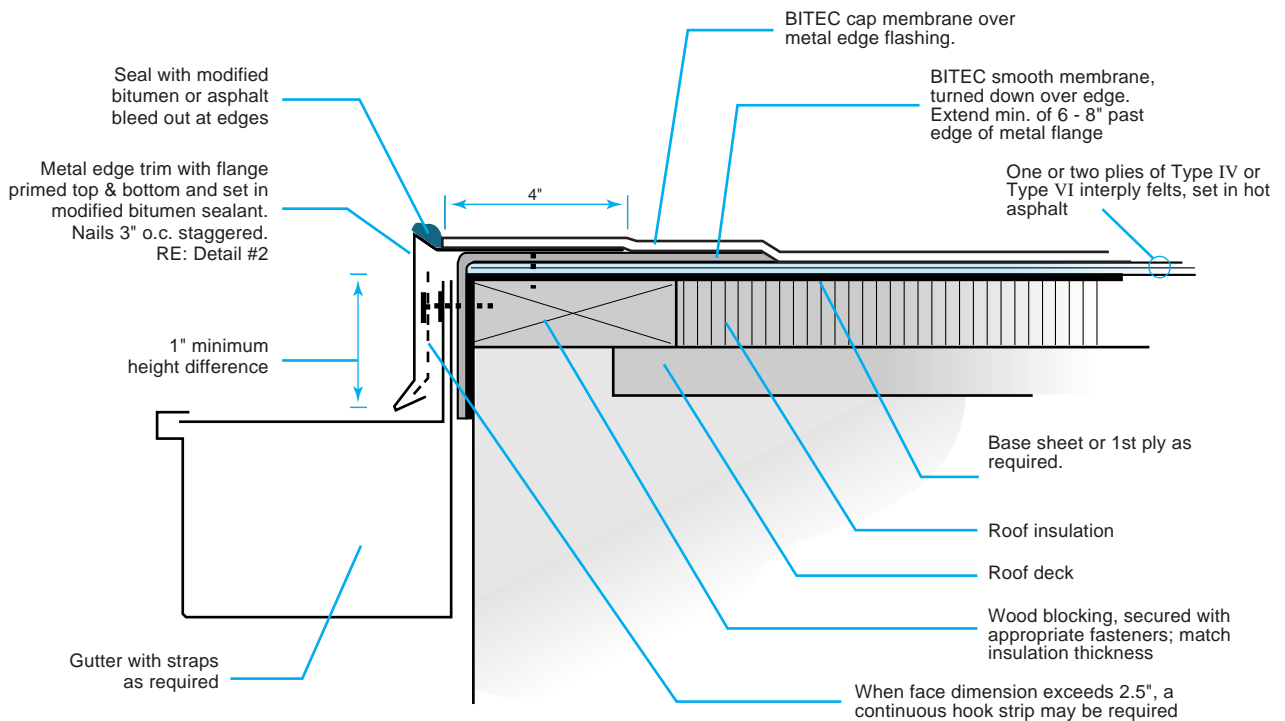

CAUTION: This alternate edge detail is not in compliance with FM Loss Prevention Data Bulletin I-49 for Perimeter Flashings

BUR MOD 2. Flat Draining Edge (Drip Edge, Gravel Stop)

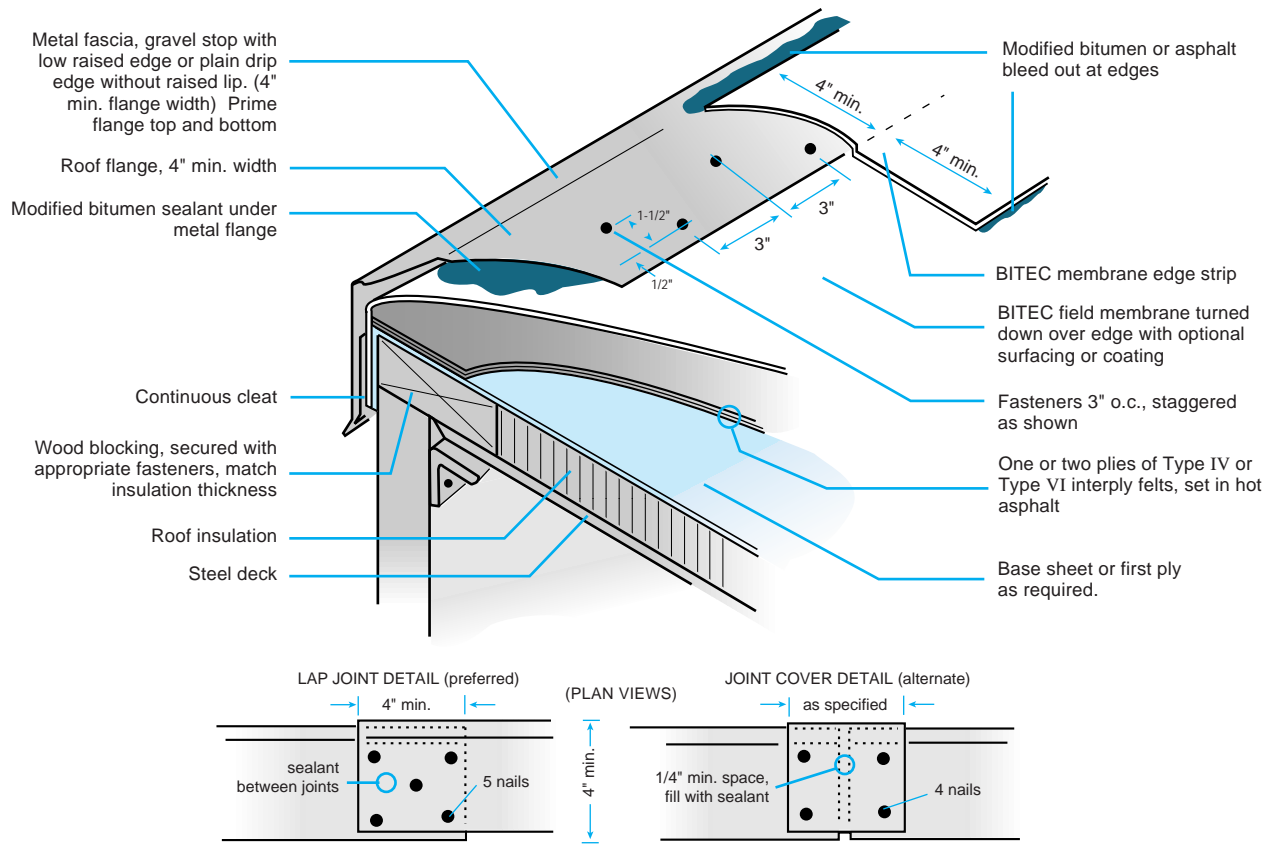

BUR MOD 2a. Flat Draining Edge (Drip Edge, Gravel Stop), alternate

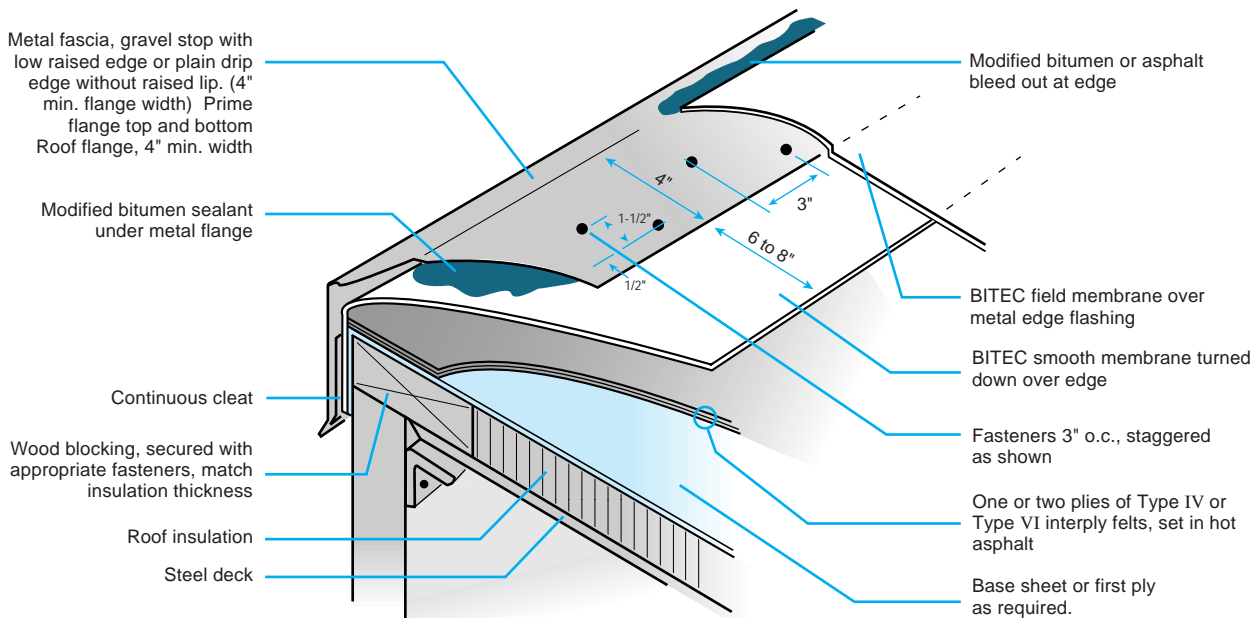

(See Lap Joint detail - #2)

CAUTION: This alternate edge detail is not in compliance with FM Loss Prevention Data Bulletin I-49 for Perimeter Flashings

BUR MOD 7. Multi-Ply Base Flashing at Plywood Parapets

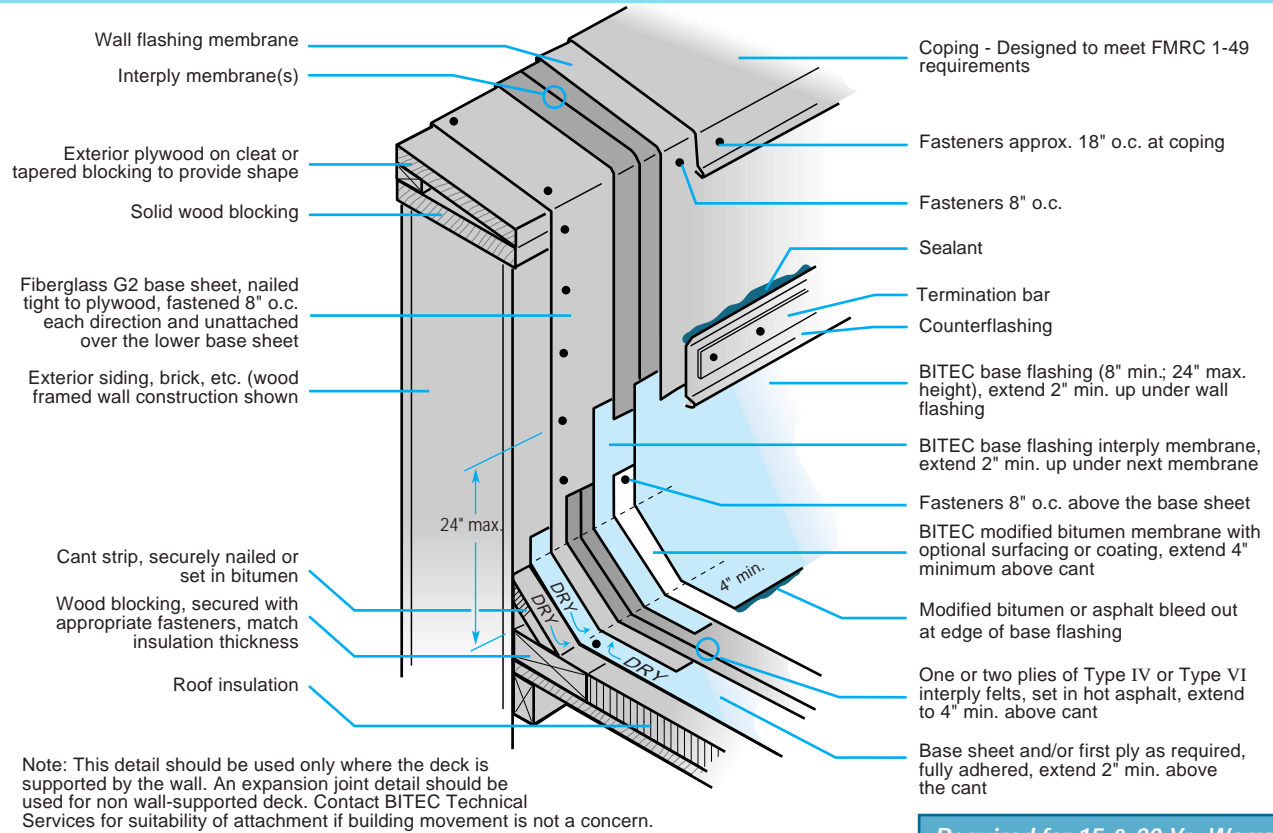

Required for 15 & 20 Yr. Warranty

BUR MOD 7A. Base Flashing at Plywood Parapets

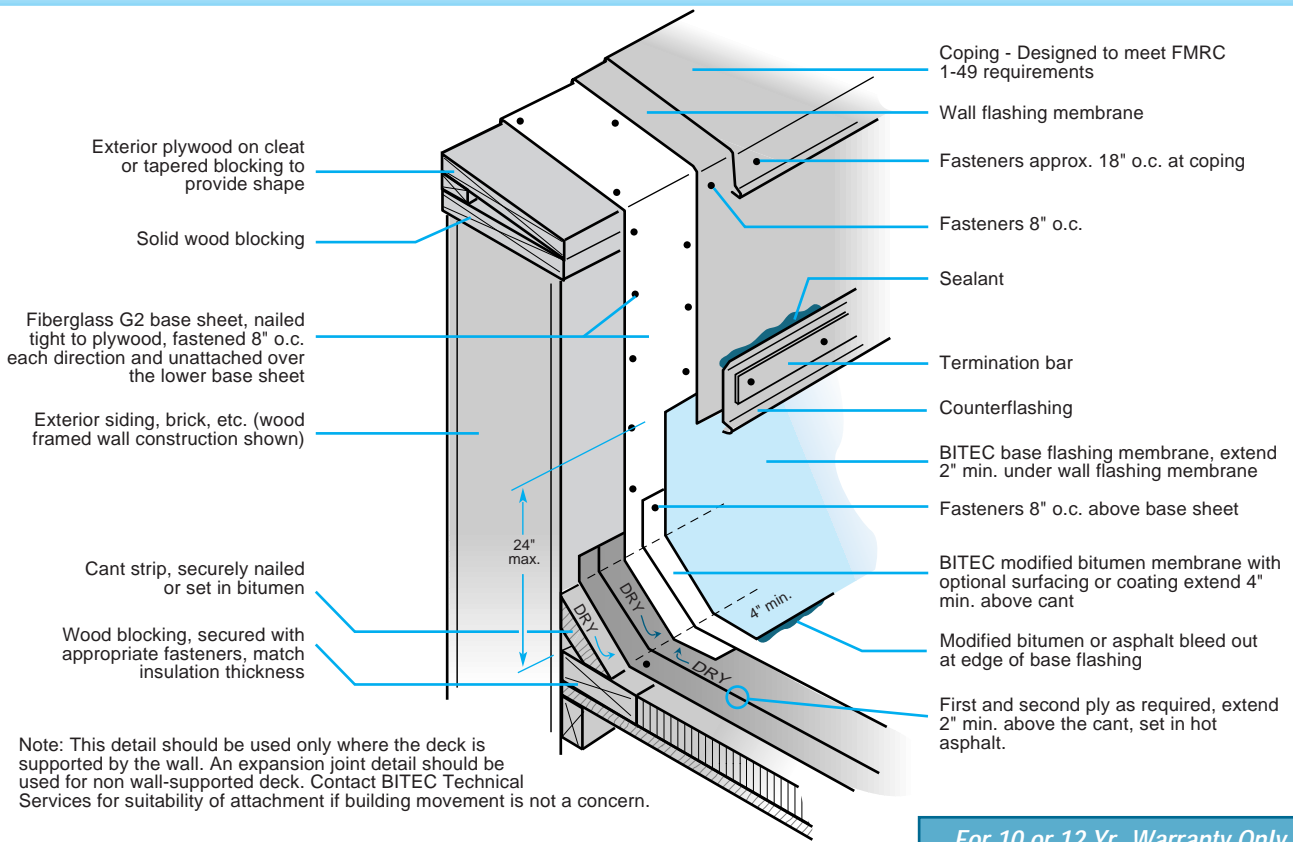

For 10 or 12 Yr. Warranty Only

7B. High Parapet Base Flashing at Masonry Walls

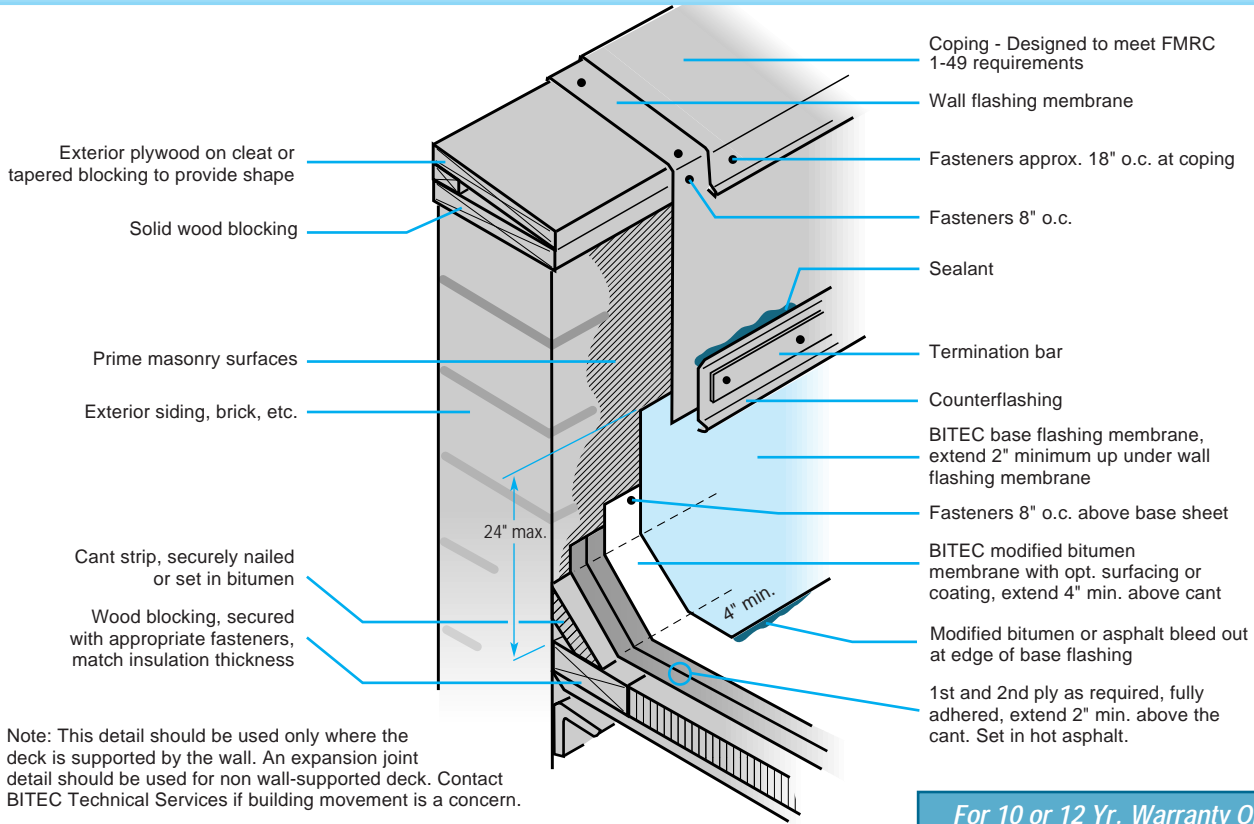

For 10 or 12 Yr. Warranty Only

7C. Multi-Ply Base Flashing at Masonry Parapets

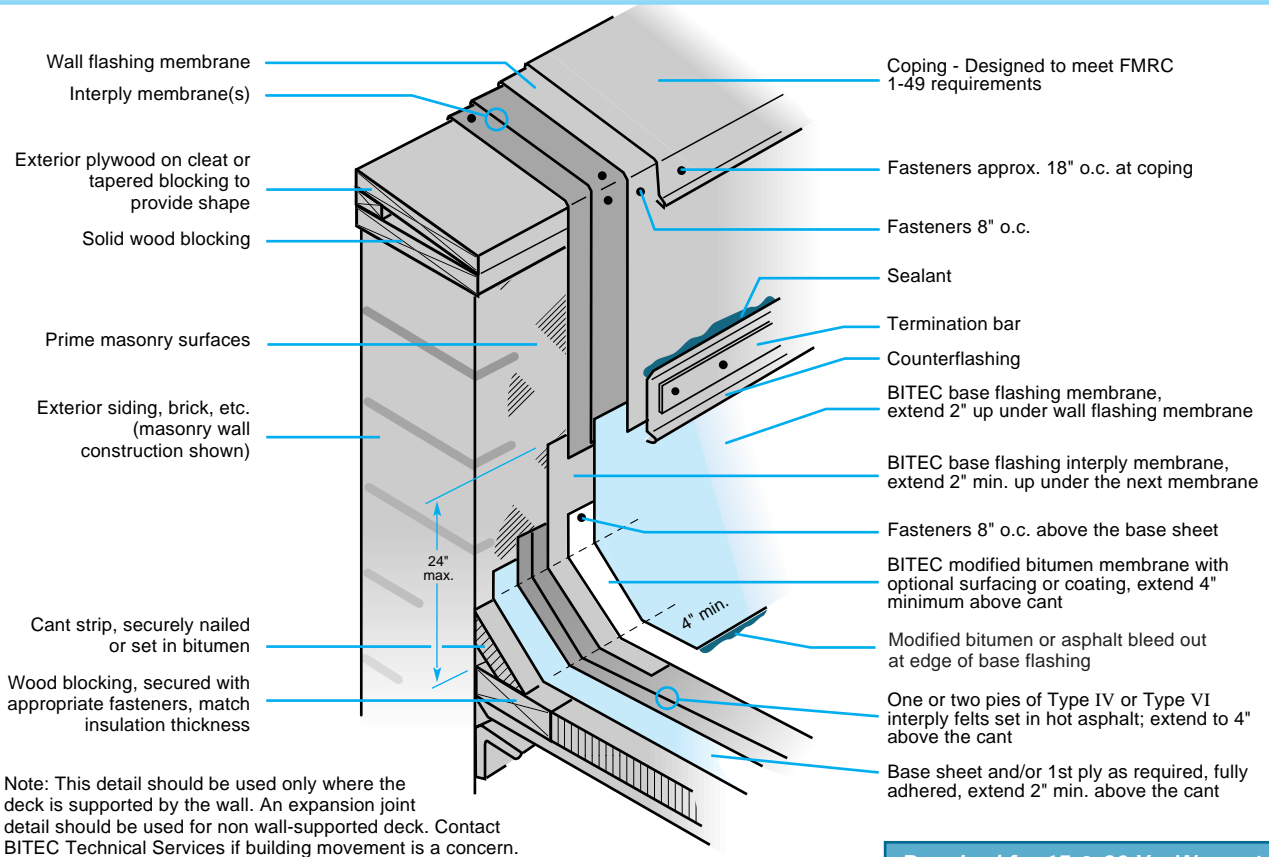

Required for 15 & 20 Yr. Warranty

BUR MOD 28. Plumbing Vent Flashing

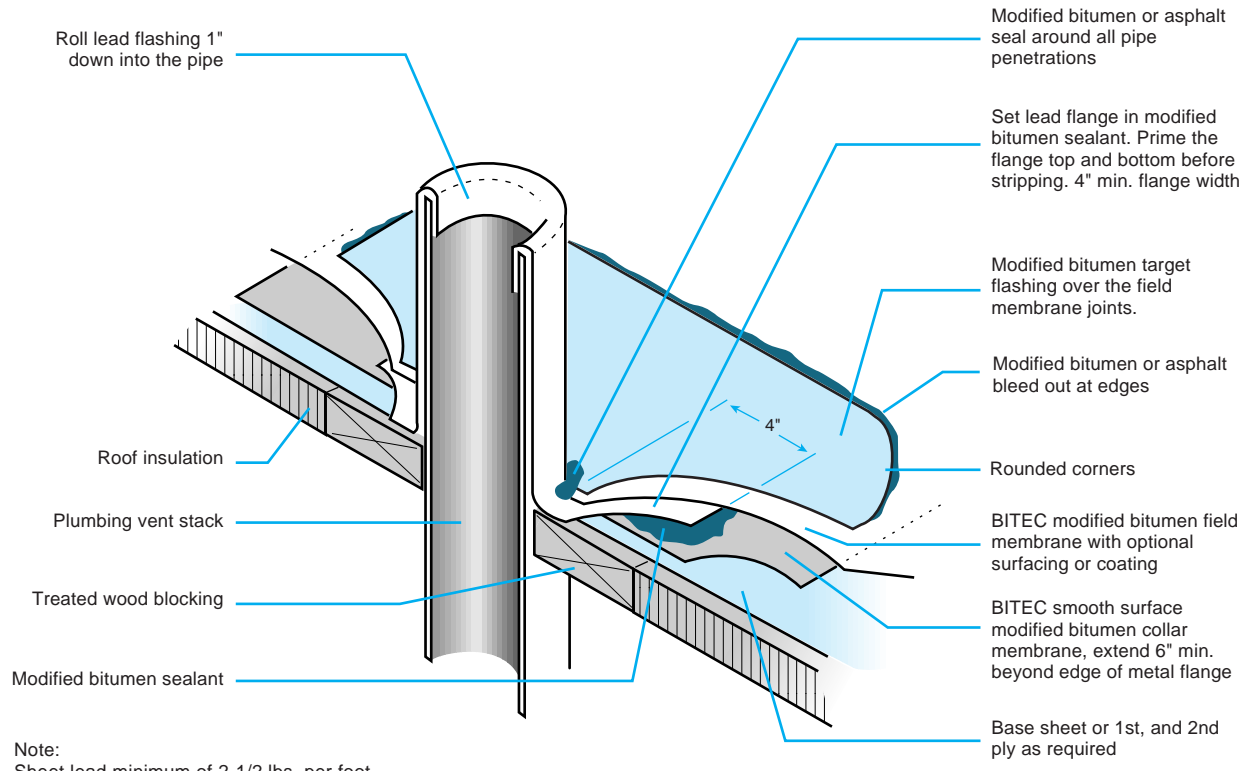

Note:
Sheet lead minimum of 2-1/2 lbs. per foot.

For 10 or 12 Yr. Warranty Only

BUR MOD 30. Hot Stack Flashing Curb

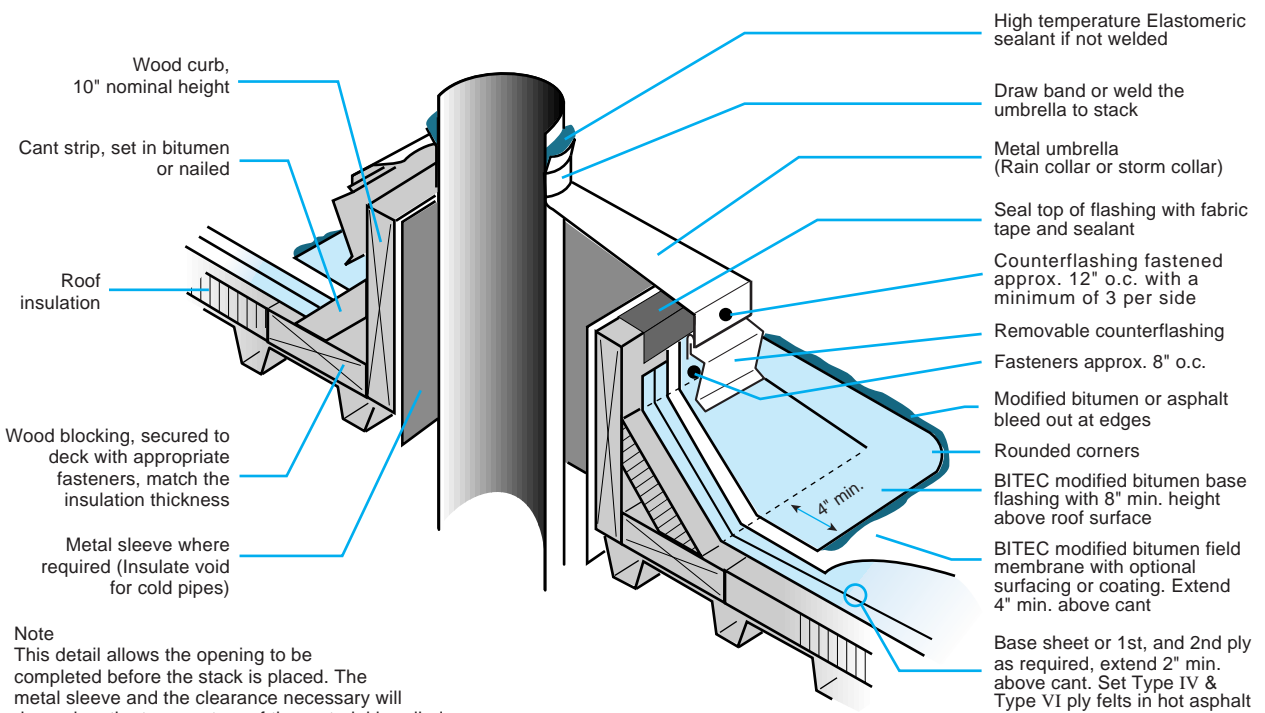

Note
This detail allows the opening to be completed before the stack is placed. The metal sleeve and the clearance necessary will depend on the temperature of the material handled by the stack.

For 10 or 12 Yr. Warranty Only

NOTES

All Information is given in good faith, but normal tolerances of manufacture and testing will apply. BITEC reserves the right to improve and change its products at any time without prior notice or advice. The use of BITEC products is determined by local conditions and indi-

vidual requirements of each contract. In consideration of the many factors involved, BITEC cannot be held responsible for the application of its products and for conditions beyond its control. All claims filed against BITEC warranties will be subject to the provisions set

forth at the date of warranty issuance, and any addendums thereto. Under no circumstances will BITEC be held liable for any damage, whether personal injury or property damage, which occur during or after the application of the membrane.

#4-3M-01/02-6



Visit our web site at www.bi-tec.com

MANUFACTURERS OF ADVANCED TECHNOLOGY WATERPROOFING MEMBRANES
P.O. Box 497 • Morrilton, Arkansas 72110 • Fax (501) 354-3019 • Phone (800) 535-8597